

# FUHO

## Vertical Bandsaw



# FBS-1200



MODEL	FBS-1200
MAX. THROAT CAPACITY	508 mm ; 20 inch
MAX. WORK HEIGHT	505 mm ; 20 inch
WHEEL DIAMETER	560 mm ; 22 inch
BLADE SPEED	15 - 90 M/min ; 50 -300 F/min
BLADE LENGTH	41 x 4480 mm ; 176-3/8 inch
MAIN DRIVE MOTOR	7.5HP ; 5.5 KW x 3PH x 4P
HYDRAULIC MOTOR	2HP ; 1.5 KW x 3PH x 4P
COOLING MOTOR	1/4HP ; 0.2KW x 3PH x 2P
TABLE FEED POWER	Hydraulic
TABLE STROKE	1200 mm ; 47-1/2 inch
TABLE SIZE	980 x 1320 mm ; 38-3/4 x 52 inch
TABLE HEIGHT	1000 mm ; 39-3/8 inch
TABLE Wt. CAPACITY	2000 kgs
FLOOR SPACE	1450 x 3460 mm ; 57 x 136-1/4 inch
OVERALL HEIGHT	2400 mm ; 94-1/2 inch
NET WEIGHT	3850 kgs

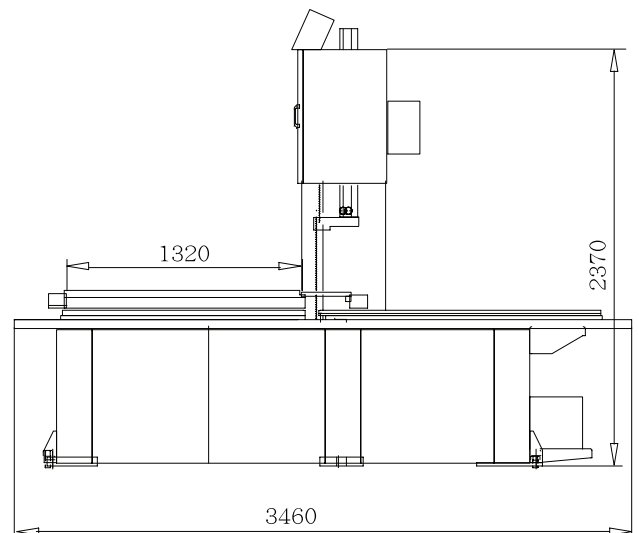

# VBS-1408



MODEL	VBS-1408	VBS-1408E
MAX. THROAT CAPACITY	356 mm ; 14 inch	
MAX. WORK HEIGHT	205 mm ; 8 inch	
WHEEL DIAMETER	368 mm ; 14-1/2 inch	
BLADE SPEED	60Hz	25 - 100 M/min ; 82 - 330 F/min
	50Hz	20 - 80 M/min ; 65 - 265 F/min
MAIN DRIVE MOTOR	1 HP ; 0.75 KW x 3PH	
TABLE SIZE	500 x 500 mm 20 x 20 inch	500 x 600 mm 20 x 24 inch
TABLE TILT	R-15° , L-12° 8° EACH F&B	5° EACH L&R FLAT F&B
TABLE HEIGHT	990 mm ; 39 inch	
MAX. BLADE LENGTH	2890 mm ; 113-3/4 inch	
MAX. BLADE WIDTH	13 mm ; 1/2 inch	
MEASUREMENT	850 x 600 x 1740 mm 34 x 24 x 68-1/2 inch	
NET WEIGHT	275 kgs	335 kgs
TABLE FEED POWER		80Kgcm, 110V
TABLE STROKE		300mm; 12 inch

## STANDARD EQUIPMENT

KEY SWITCH/ EMERGENCY STOP SWITCH



BLADE WELDER/ GRINDER/ SHEAR



110 VOLT WORK LIGHT

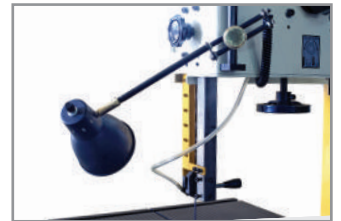

RIP FENCE

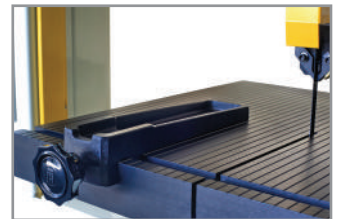

BLADE TENSION INDICATOR



CHIP BLOWER

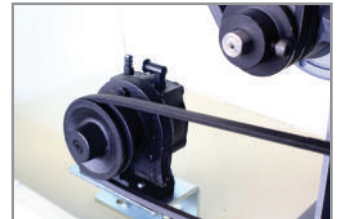

SPEED INDICATOR



# VBS-1610E-CE



## STANDARD EQUIPMENT

KEY SWITCH/ EMERGENCY STOP SWITCH



BLADE WELDER/ GRINDER/ SHEAR



110 VOLT WORK LIGHT

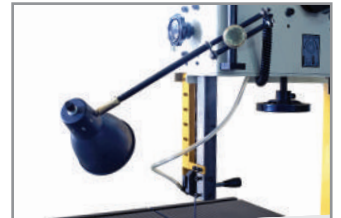

RIP FENCE

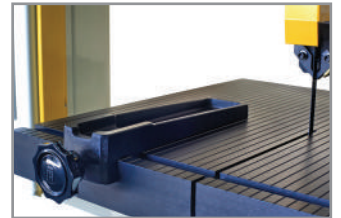

UPPER WHEEL TILT ADJUSTER  
BLADE TENSION INDICATOR



CHIP BLOWER

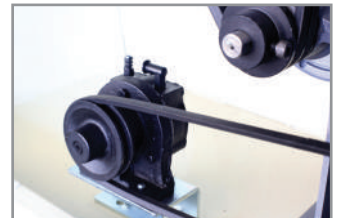

SPEED INDICATOR



MODEL		VBS-1610	VBS-1610E
MAX. THROAT CAPACITY		396 mm ; 16 inch	
MAX. WORK HEIGHT		255 mm ; 10 inch	
WHEEL DIAMETER		408 mm ; 16 inch	
BLADE SPEED	60Hz	Low 25-100 , HI 300-1200 M/min Low 82-330 , HI 985-3950 F/min	
	50Hz	Low 20 - 80 , HI 250-1000 M/min Low 65-265 , HI 820-3280 F/min	
MAIN DRIVE MOTOR		2 HP ; 1.5 KW x 3PH	
TABLE SIZE		550 x 600 mm ; 22 x 24 inch	
TABLE TILT		R-15° , L-12° 8° EACH F&B	5° EACH L&R FLAT F&B
TABLE HEIGHT		1000 mm ; 39-3/8 inch	
MAX. BLADE LENGTH		3150 mm ; 124 inch	
MAX. BLADE WIDTH		16 mm ; 5/8 inch	
MEASUREMENT		940 x 675 x 1840 mm 37 x 26-1/2 x 72-1/2 inch	
NET WEIGHT		410 kgs	435 kgs
TABLE FEED POWER			80 Kgcm, 110V
TABLE STROKE			300 mm ; 12 inch

# VBS-2012



## STANDARD EQUIPMENT

KEY SWITCH/ EMERGENCY STOP SWITCH  
DIGITAL READOUT TACHOMETER



BLADE WELDER/ GRINDER/ SHEAR



110 VOLT WORK LIGHT

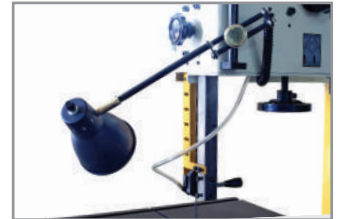

RIP FENCE

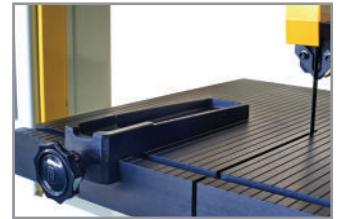

UPPER WHEEL TILT ADJUSTER  
BLADE TENSION INDICATOR

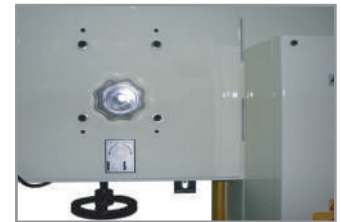

CHIP BLOWER

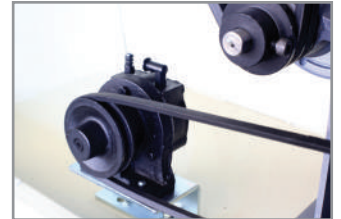

POST ELEVATING HANDWHEEL



MODEL	VBS-2012	
MAX. THROAT CAPACITY	508 mm ; 20 inch	
MAX. WORK HEIGHT	305 mm ; 12 inch	
WHEEL DIAMETER	515 mm ; 20-1/2 inch	
BLADE SPEED	50/60Hz	Low 20 -180 , HI 120 - 1000 M/min Low 65 -585 , HI 390 - 3280 F/min
MAIN DRIVE MOTOR	2 HP ; 1.5 KW x 3PH	
TABLE SIZE	600 x 560 mm 24 x 22-1/2 inch	
TABLE TILT	15° EACH L&R , 8° EACH F&B	
TABLE HEIGHT	1000 mm ; 39-3/8 inch	
MAX. BLADE LENGTH	3970 mm ; 156-1/4 inch	
MAX. BLADE WIDTH	27 mm ; 1 inch	
WELDER CAPACITY	19 mm ; 3/4 inch	
MEASUREMENT	1075 x 765 x 2000 mm 42 x 30 x 79 inch	
NET WEIGHT	510 kgs	

## VBS-2012H-CE



## VBS-2613



MODEL	VBS-2012H	VBS-2012HE	VBS-2613	VBS-2613E	VBS-3612	VBS-3612E
MAX. THROAT CAPACITY	508 mm ; 20 inch		658 mm ; 26 inch		915 mm ; 36 inch	
MAX. WORK HEIGHT	305 mm ; 12 inch		330 mm ; 13 inch		305 mm ; 12 inch	
WHEEL DIAMETER	515mm X 2 ; 20-1/4 inch X 2		665 mm X 2 ; 26-1/4 inch X 2		515 mm X 2 ; 20-1/4 inch X 2 368 mm X 1 ; 14-1/4 inch X 1	
BLADE SPEED	Low 15 - 125, HI 165 - 1500 M/min Low 50 - 415, HI 550 - 5000 F/min		Low 15 - 125, HI 165 -1500 M/min Low 50 - 415, HI 550 - 5000 F/min		Low 15 - 125, HI 165 -1500 M/min Low 50 - 415, HI 550 - 5000 F/min	
MAIN DRIVE MOTOR	3 HP ; 2.2 KW x 3PH		3 HP ; 2.2 KW x 3PH		3 HP ; 2.2 KW x 3PH	
TABLE SIZE	600 x 700 mm 23-1/2 x 27-1/2 inch		600 x 700 mm 23-1/2 x 27-1/2 inch		600 x 700 mm ; 23-1/2 x 27-1/2 inch 450 x 700 mm ; 17-1/2 x 27-1/2 inch	
TABLE TILT	R-45° , L-10°		R-45° , L-10°		R-45° , L-10°	
TABLE HEIGHT	1016 mm ; 40 inch		1000 mm ; 39-3/8 inch		1016 mm ; 40 inch	
MAX. BLADE LENGTH	4035 mm ; 158-3/4 inch		4680 mm ; 184-1/4 inch		5020 mm ; 197-1/2 inch	
MAX. BLADE WIDTH	27 mm ; 1 inch		27 mm ; 1 inch		27 mm ; 1 inch	
WELDER CAPACITY	19 mm ; 3/4 inch		19 mm ; 3/4 inch		19 mm ; 3/4 inch	
MEASUREMENT	1090 x 810 x 2030 mm 43 x 32 x 80 inch		1295 x 810 x 2140 mm 51 x 32 x 84 inch		1760 x 810 x 2060 mm 69 x 32 x 81 inch	
NET WEIGHT	590 kgs	625 kgs	665 kgs	700 kgs	800 kgs	835 kgs
TABLE FEED POWER		80 kgcm, 110V		80 Kgcm, 110V		80 Kgcm, 110V
TABLE STROKE		300 mm ; 12 inch		300 mm ; 12 inch		300 mm ; 12 inch

# VBS-3612E



## STANDARD EQUIPMENT

MITER PROTRACTOR

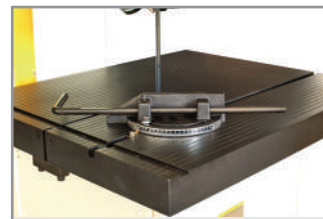

MANUAL FEED SCREW



CIRCULAR CUTTING ATTACHMENT

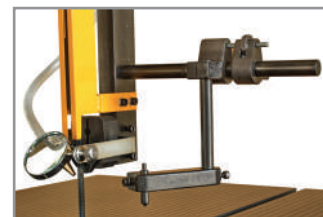

MAGNIFYING GLASS



110 VOLT WORK LIGHT



CHIP BLOWER



MAINTAIN SWITCH



	A	B	C	D	E	F	G	H	J
VBS-2012H	2030	305	1016	508	N/A	600	1090	700	810
VBS-2613	2190	330	1000	658	N/A	600	1340	700	810
VBS-3612	2060	305	1016	915	450	600	1760	700	810

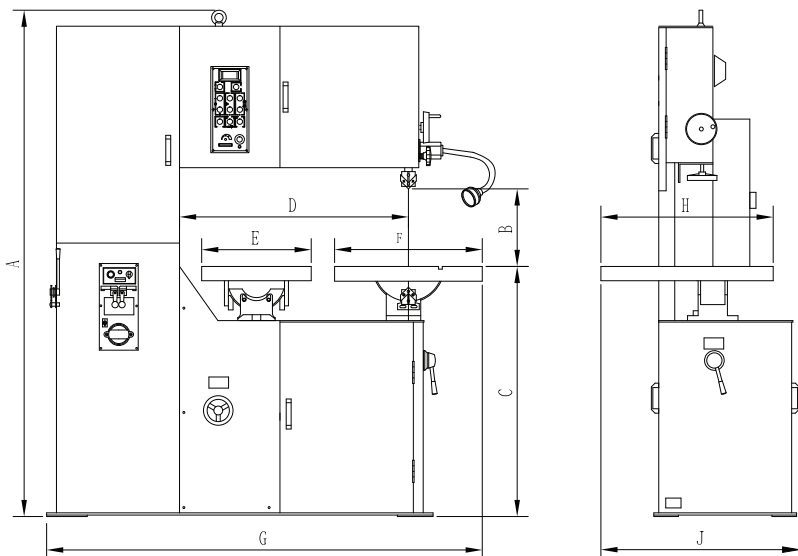

# Butt Welders



**FBW-24**

**FBW-72**

MODEL			FBW-12	FBW-24	FBW-42	FBW-72
CAPACITY			1.2 KVA	2.4 KVA	4.2 KVA	7.2 KVA
ABILITY						
CARBON STEEL	mm		2-13	3-16	6-19	3-25
	inch		1/8-1/2	1/8-5/8	1/4-3/4	1/8-1
BI-METAL, TUNGSTEN	mm			2-13	3-16	6-19
	inch			1/8-1/2	1/8-5/8	1/4-3/4
DIMENSION	L	mm	265	265	265	445
		inch	10½	10½	10½	17¾
	W	mm	260	260	260	335
inch		10½	10½	10½	14¼	
H	mm	400	400	400	450	
	inch	16	16	16	16	
NET WEIGHT	kg		17	20	25	60
	lb		37	44	55	132

FU HO FACTORY CO., LTD  
 76, CHIENKUO 2ND ROAD, SINCHUANG,  
 TAIPEI, TAIWAN, R.O.C.  
 TEL: +886-2-2202-0890  
 FAX: +886-2-2202-0891  
 E-MAIL: fuho1533@ms35.hinet.net  
<http://fu-ho.myweb.hinet.net>



**FU HO FACTORY CO., LTD.**  
 VERTICAL BANDSAW MACHINE SPECIALIZED MANUFACTURER.

SINCE 1967