



鎂佳機械工業股份有限公司  
**MEGA MACHINE CO.,LTD.**

台灣 · 411014台中市太平區工業路180號  
No.180, Industrial Road, Tai-ping District, Taichung City, 411014, Taiwan R. O. C.  
www.bandsaw.com.tw  
Tel:+886-4-22712877(Rep.) Fax: +886-4-22715016  
E-Mail: sales@bandsaw.com.tw



Official Website



www.bandsaw.com.tw

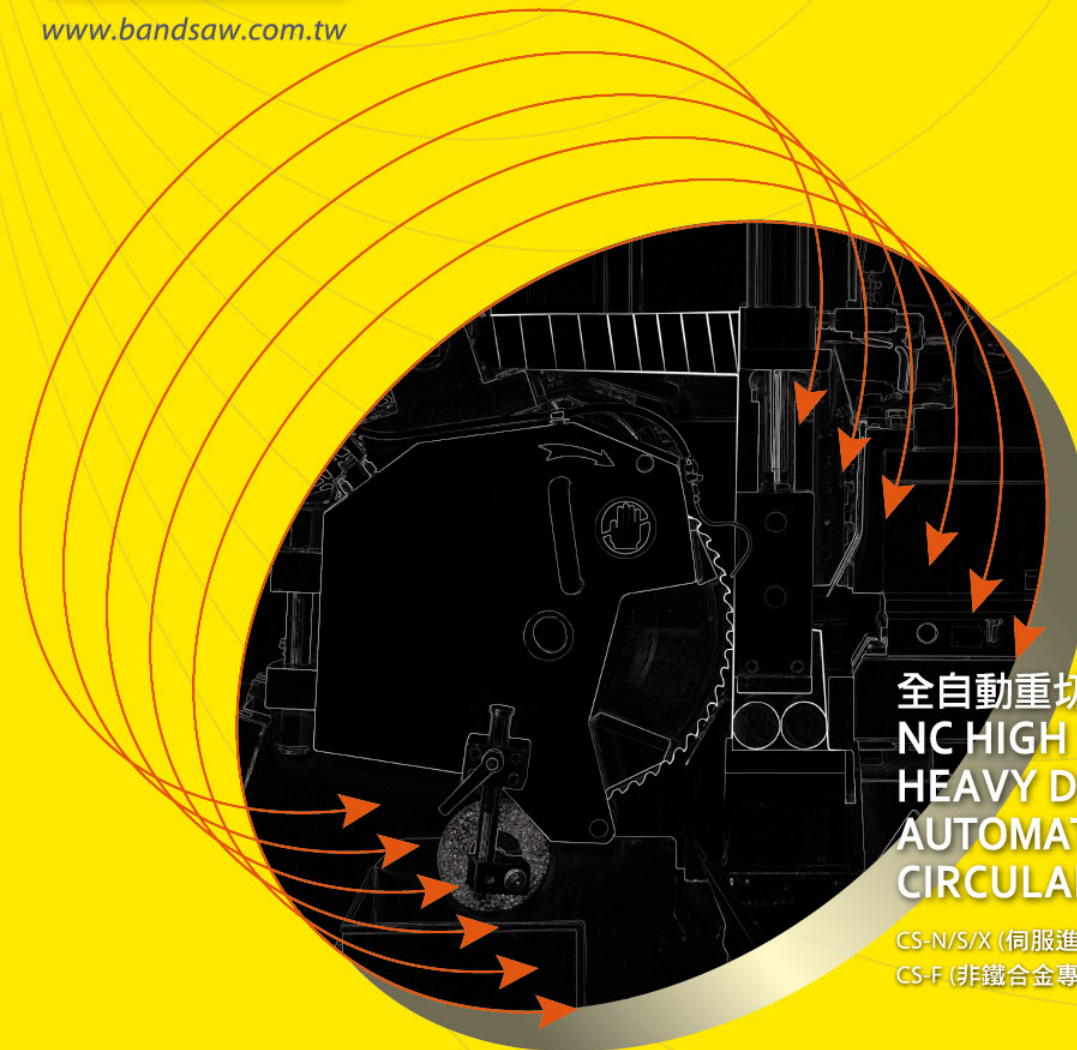

全自動重切削高速圓鋸機  
**NC HIGH SPEED  
HEAVY DUTY  
AUTOMATIC CARBIDE  
CIRCULAR SAW**

CS-N/S/X (伺服進刀 Servo Motor Feedrate)  
CS-F (非鐵合金專用 Nonferrous Metal Cutting)

Keep Improving & Quality Oriented - Skillful engineering and imaginative design give every MEGA Circular Saw Machine exceptional cutting capacity.  
不斷創新與精進&嚴格執行品質要求-以操作者為出發點的設計,並追求完美的品質

CS 系列特色 CS SERIES FEATURES	P3
機台外觀尺寸 MACHINE DIMENSIONS	P6
全自動重切削高速圓鋸機 (切鐵金屬) NC HIGH SPEED HEAVY DUTY AUTOMATIC CARBIDE CIRCULAR SAW (FERROUS METAL CUTTING)	P7
CS-80X	P7
CS-75N/ 120N/ 160N	P9
CS-180N/ 230N	P11
CS-150S	P13
全自動重切削高速圓鋸機 (切非鐵金屬) NC HIGH SPEED HEAVY DUTY AUTOMATIC CARBIDE CIRCULAR SAW (NONFERROUS METAL CUTTING )	P13
CS-75F/ 120F	P15
CS-150F	P17
選擇配備 OPTIONAL EQUIPMENT	P19



### 不斷創新與精進

今天做得要比昨天做得更好，明天做得要比今天做得還要好，是我們不斷創新，研究發展的精神所在。因為我們深知沒有成長就是退步，沒有創新就是落伍。鎂佳所以兢兢業業，奮發努力，為的是要提供經濟、完美的產品，貢獻業界來降低生產成本，減少胚料損失，提高生產能量，增進原胚料精度，提升自動化程度，促進技術升級，減少能源浪費。

### 嚴格執行品質要求

我們把機器當作是藝術品來處理，每個過程小心翼翼，要求盡善盡美，不容許有任何瑕疵。因為我們知道，為客戶提供完善的售後服務，不厭其煩的服務態度並不能使客戶完全滿足，唯有完美的品質，近乎免於服務的機器，才是我們追求的最大目標。

### 以操作者為出發點的設計

客戶的要求，操作者的願望，是本公司一系列機械設計的參考藍本，以機器來配合人們的操作，而不是以人來配合機器，正是我們全力追求的目標，因此，鎂佳的圓鋸機，結構剛強，操作容易，安全性高，鋸切能力強勁快速，精密度高，機件、鋸片持久耐用生產能量大，人工最省。

### 精良產品永續經營

鎂佳機械工業股份有限公司，創立於西元 1980 年，成立以全自動油壓帶鋸機、NC 全自動圓鋸機、精密油壓滾牙機、CNC 螺絲磨床之研發、製造、組裝及銷售服務的專業廠商。

### KEEP IMPROVING

MEGA's R&D has over thirty-year experiences thus forms a strong team. It can provide total solution in screw and gear rolling, metal and nonferrous cutting, worm and thread grinding.

### QUALITY ORIENTED

MEGA quality policy: "High performance and best quality can catch customers' heart, turning quality into company's "Super Salesman".

### CUSTOMIZED FOR YOU

MEGA could provide total solution to meet your production requirement.

### PERPETUAL MANAGEMENT

Since 1980,MEGA machine Co.,Ltd has been specializing in designing, producing and assembling, serving customers with bandsaw machine, NC circular saw machine, thread rolling machine and CNC thread grinding machine.

隨研發的改進，本公司保有設計變更產品規格的權力與解釋權，確定規格、尺寸、產品資訊以實品為準，若有變更恕不另行通知。 Specifications are subject to change for improvement and modification without prior notice.

# CS-N/X/S/F 全自動重切削高速圓鋸機

## NC HIGH SPEED HEAVY DUTY AUTOMATIC CARBIDE CIRCULAR SAW

精準  
PRECISE

### 機械電子整合控制 MECHATRONICS CONTROL

機械透過數值控制、伺服送料與進刀，並配合改良後的碳化鎢刀具，達到高速精密切削，切斷面平整的效果。High speed precision cutting with an almost ground finish surface and excellent repeatability has been made possible by numeric control, servo motor feeding cut-off and bar feed, and vastly improved carbide saw blade.

快速  
FAST

### 更快的切削速度 CUTTING FASTER

#### CS-N、CS-S 系列 CS-N、CS-S Series

適用於一般鋼材，不銹鋼等，比傳統 HSS 鋸片的切削速度快達 5 倍。  
Suitable for cutting most steels & alloys ranging from structural to stainless steels (SS,SC,SUS).  
Cutting speed is 5 times faster than machine with HSS blade.

#### CS-F 系列 CS-F Series

切非鐵類 (如鋁、銅、塑鋼) 專用機，鋸切速度比油壓切鋁機快 10 倍。  
Designed especially for cutting nonferrous metal, such as aluminum alloy, copper, plastic steel. 10 times faster than cutting by machine with conventional HSS blade.

堅固  
STABLE

### 鋸片壽命更長 ENHANCE BLADE SERVICE LIFE

堅固結構與防震設計提升切削速度並延長鋸片壽命。  
Rigid structure and anti-vibration design ensure excellent and accurate repeatability with finishing cut surface for high-speed cutting and longer saw blade life.

輕薄  
THIN

### 耗材更少 LESS MATERIAL CONSUMING

改良後的碳化鎢圓鋸片刀身更薄，耗材更少並可降低刀具磨耗，減低耗電量。  
Vastly improved carbide saw blade is thinner, achieving less material consuming and resulting in less blade wear and less power consumption.

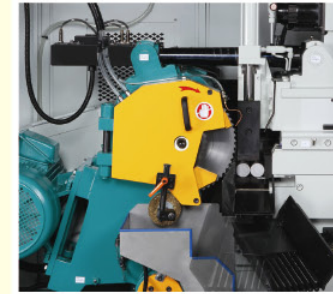

### 判別系統

自動化切削中自動分辨端材，殘材於不同料桶中。

### SEPARATING SYSTEM

Separator automatically separates trim edge cut and residue into different storage tanks.



### 上壓夾鉗

切削單支或 2 支工件時，防止快速切削時衍生的震動。

### OVERHEAD CLAMPING VISE JAW

Ensure material being clamped firmly and avoid vibration while fast cutting single bar or 2 pieces same size bar at one time.



### 油壓搖擺床座

配合伺服滾珠螺桿系統，能對彎曲工件良好運送，確保工件被切削時能達最小的磨耗以及最大的精度。

### FLOATING SWIVELABLE REAR VISE SADDLE

This hydraulic floating rear vise saddle, linked to the servo motor and ball screw, is excellent for gripping and delivering even bowed or bent bar, ensuring minimum worn surface and greatest cutting accuracy.

# CS-N/X/S/F 全自動重切削高速圓鋸機

## NC HIGH SPEED HEAVY DUTY AUTOMATIC CARBIDE CIRCULAR SAW



### 獨特齒輪箱設計

獨特齒輪傳動系統設計確保切削過程平順無雜音，提高切削效能，減少耗電量，並可延長圓鋸片壽命。

### UNIQUE GEAR HEAD DESIGN

The unique gear transmission system ensures smooth cutting with high efficiency, less noise, and low power consumption, and enhances saw blade service life.



### 模組化設計

獨立式油噴霧系統模組化，可自行設定控制間接或連續性噴霧時間，大幅節省切削油的使用，當切削油量不足時也將自動發出警示提醒。

### UP TO DATE MODULE

Modularized oil mist spraying mode can be set as:

1. Intermittent spraying
2. Continuously spraying for optimized mist oil consumption. When the cutting oil is not enough, then error signal will pop-out to notify the operator to refill it.

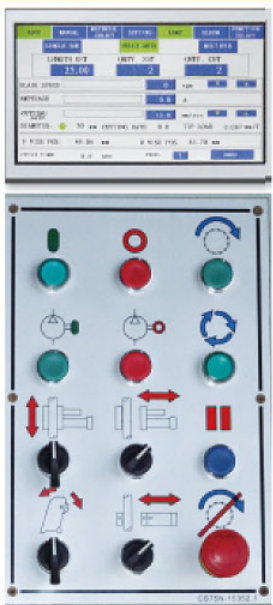

### 人機介面控制

1. 機電整合的人性化觸控螢幕。
2. 簡易設定各項數值與切削模式。
3. 多項安全偵測監控程式之設計，可顯示故障因素及維修對策。

### TOUCH SCREEN CONTROL

It's a fuzzy, graphic, colorful, digital and tactile control panel, allowing easy presetting for various work-piece. It has an automatic detector display to indicate operational errors and causes of malfunctions.

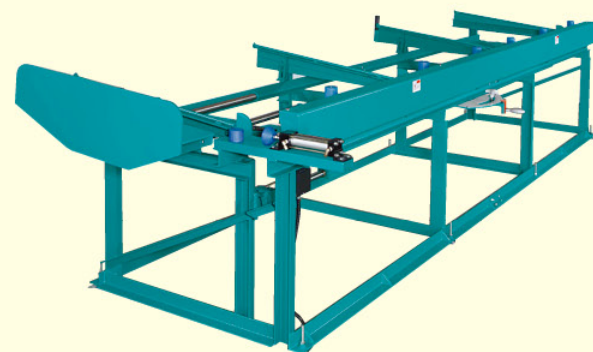

### 進料架

標準進料架能調整不同材料外徑大小，可放置材料長至6公尺。另可依進料需求客製尺寸與功能。

### MAGAZINE TABLE

Magazine table holds 6 meters long material for loading different sizes of bars. Customized bar loading system is optional for different applications.

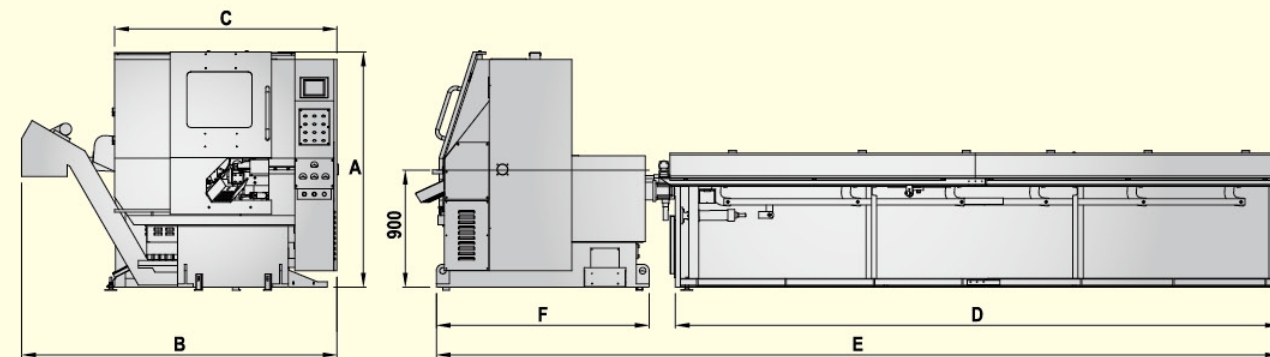

機型 MODEL	單位 UNIT	A	B	C	D	E	F
CS-75N	mm	1809	2410	1712	4650	6489	1638
	inch	71.2	94.9	67.4	183	255.4	64.5
CS-120N	mm	1820	2845	1985	4700	6580	1638
	inch	71.7	112	78.1	185	259	64.5
CS-160N	mm	2011	3370	2280	-	-	1696
	inch	79.2	132.7	89.8	-	-	66.8
CS-180N	mm	2025	3560	2540	-	-	1710
	inch	79.7	140.2	100	-	-	67.3
CS-230N	mm	2161	3769	2760	-	-	1698
	inch	85.1	148.4	108.7	-	-	66.9
CS-80X	mm	1880	2450	1825	4690	6515	1638
	inch	74	96.5	71.9	184.6	256.5	64.5
CS-75F	mm	1830	2410	1720	4690	6500	1638
	inch	72	94.9	67.7	184.6	255.9	64.5
CS-120F	mm	1820	2845	1985	4700	6580	1638
	inch	71.7	112	78.1	185	259	64.5
CS-150S/150F	mm	1855	2900	2160	4700	6940	1638
	inch	73	114.2	85	185	273.2	64.5

### 料架尺寸規格 MAGAZINE TABLE DIMENSIONS

規格 / 機型 SPEC. / MODEL	單位 UNIT	CS-75F	CS-120F	CS-150S/150F
承載能力 Capacity	mm	ø75 x 6000L x 13 支 pcs	ø120 x 6000L x 8 支 pcs	ø150 x 6000L x 6 支 pcs
	inch	ø2.76 x 236.2 x 13 支 pcs	ø4.72 x 236.2L x 8 支 pcs	ø5.91 x 236.2L x 6 支 pcs
料架尺寸 Size	mm	5700 L x 1600 W	5700 L x 1500 W	5700 L x 1550 W
	inch	224.4 L x 63 W	224.4 L x 59 W	224.4 L x 61 W

# CS-80X NC 全自動切削高速圓鋸機

## NC HIGH SPEED AUTOMATIC CARBIDE CIRCULAR SAW



### 規格表 Specifications

規格 / 機型 SPEC. / MODEL		CS-80X
工作規格 Cutting Capacity	mm	● 10 ~ 80 (285 鋸片) ■ 10 ~ 60
	in	● 0.39 ~ 3.14 (11.22 鋸片) ■ 0.39 ~ 2.36
馬達馬力 Motor Output	HP	圓鋸驅動馬達 Blade-20 油壓幫浦馬達 Hyd.-2 送料伺服馬達 Bar Feed Servo -1.3 進刀伺服馬達 Servo Feedrate -4.69
鋸片尺寸 Blade Size	mm	( $\phi$ 280) $\phi$ 285 X $\phi$ 32 X T2.0 Z: 72t, 80t
	in	( $\phi$ 11.02) $\phi$ 11.22 X $\phi$ 1.26 X T 0.079 Z: 72t, 80t
圓鋸迴轉速度 Blade Speed	rpm	56 ~ 225 無段變頻可調 Inverter Controlled Variable Speed
進刀方式 Blade Feed Cut	.	AC 伺服馬達 + 滾珠螺桿 AC Servo Motor + Ball Screw
送料方式 Bar Feed	.	AC 伺服馬達 + 滾珠螺桿 AC Servo Motor + Ball Screw
切斷長度 Auto Feed Length	mm	一次送料 Single Feed 6~600 (選配 Opt. 6~700) / 二次送料以上 Multiple Feed 600~9999 (選配 Opt.700~9999)
	in	一次送料 Single Feed 0.23~23.62 (選配 Opt. 0.23~27.5) / 二次送料以上 Multiple Feed 23.62~393.6 (選配 Opt. 27.5~393.6)
端材尺寸 Trim-cut Length	mm	10~120
	in	0.39~4.7
殘料長度 Residue Length	mm	35~35+ 切斷長
	in	1.37~1.37+ 切斷長
自動清屑機構 Auto Chip Conveyor	.	鏈條驅動 (選配) Chain Belt Chip Conveyor (Opt.)
冷卻系統 Cooling System	.	空氣壓縮油霧 Air Compressed Oil Mist
油箱容量 Tank capacity	L	油壓幫浦 Hyd. 30, 冷卻液 Coolant 2
機台重量 N.W. / G.W.	kg	2438 / 2950
料架尺寸規格 / Magazine Table Dimensions		
承載能力 Capacity	mm	● $\phi$ 80 x 6000L x 12 支 pcs
	in	● $\phi$ 3.14 x 236.2L x 12 支 pcs
料架重量 Weight	kg	淨重 N.W 600 / 毛重 G.W 750
料架尺寸量 Size	mm	5700L x 1600W
	in	224.4L x 63W

### 標準配備 Standard Equipment

圓鋸片 Saw blade	1 片 pc
鋼刷輪 Wire brush	2 個 pcs
工作燈 Working lamp	1 組 set
工具箱 Tools with tool box	1 組 set
操作手冊 Instruction manual	1 本 copy

### 選擇配備 Optional Equipment

1. 清屑機 Auto chip conveyor.
2. 接長料架 Long cut-off pieces unloading table.
3. 整把料架 Bar stock reservoir and loader.
4. 平板工件用之鏈條式料架 Chain belt magazine table for flat work-piece.

# CS-75N/120N/160N NEW EVOLUTION SERIES

NC 全自動切削高速圓鋸機

NC HIGH SPEED AUTOMATIC CARBIDE CIRCULAR SAW



## 規格表 Specifications

規格 / 機型 SPEC. / MODEL	UNIT	CS-75N	CS-120N	CS-160N
工作規格 Cutting Capacity	mm	● 10 ~ 75 ■ 10 ~ 60	● 20~120 ■ 20~85	● 25~160 ■ 25~120
	in	● 0.39 ~ 2.95 ■ 0.6 ~ 2.36	● 0.79~4.72 ■ 0.79~3.35	● 0.98~6.3 ■ 0.98~4.72
馬達馬力 Motor Output	hp	圓鋸驅動馬達 Blade -15/4P	圓鋸驅動馬達 Blade -20/4P	圓鋸驅動馬達 Blade -30HP
		油壓幫浦馬達 Hyd -2	油壓幫浦馬達 Hyd -3	油壓幫浦馬達 Hyd -2.2
		送料伺服馬達 Bar Feed Servo -1.33	送料伺服馬達 Bar Feed Servo -2.41	送料伺服馬達 Bar Feed Servo -1.8
		進刀伺服馬達 Servo Feedrate -1.73	進刀伺服馬達 Servo Feedrate -1.73	進刀伺服馬達 Servo Feedrate -2.9
			自動清屑 Auto chip conveyor-0.46 (Optional)	
鋸片尺寸 Blade Size	mm	(Ø280) Ø285 x Ø32 x T 2.0	Ø380 x Ø40 x T2.6; Z=60	Ø480 x Ø50 x T2.7
	In	(Ø11.02) Ø11.22 x Ø1.26 x T 0.079	Ø14.96 x Ø1.57 x T0.102; Z=60	Ø18.9 x Ø1.96 x T0.106
圓鋸迴轉速度 Blade Speed	rpm	56 → 225 變頻無段可調 Inverter Controlled Variable Speed	50 → 150 變頻無段可調 Inverter Controlled Variable Speed	60 → 90 變頻無段可調 Inverter Controlled Variable Speed
進刀方式 Blade Feed Cut	-	AC 伺服馬達+滾珠螺桿 AC Servo Motor And Ball Screw		
送料方式 Bar Feed	-	AC 伺服馬達+滾珠螺桿 AC Servo Motor And Ball Screw		
切斷長度 Auto Feed Length	mm	一次送料 Single Feed 6 ~ 600 二次送料以上 Multiple Feed 600 ~ 9999		一次送料 Single Feed 6 ~ 600 二次送料以上 Multiple Feed 601 ~ 9999
	In	一次送料 Single Feed 0.23 ~ 23.62 二次送料以上 Multiple Feed 23.62 ~ 393.60		一次送料 Single Feed 0.23 ~ 23.6 二次送料以上 Multiple Feed 23.6 ~ 393.6
自動清屑機構 Auto Chip Conveyor	-	鏈條驅動(選配) Chain Belt Chip Conveyor (Optional)		
冷卻系統 Cooling System	-	空氣壓縮油霧 Air Compressed Oil Mist		
裝箱尺寸 Packing Size (LxWxH)	mm	2290 x 2240 x 2130	2550 x 2270 x 2260	Please Require From Sales Person
	ft	7.51 x 7.35 x 6.99	8.36 x 7.45 x 7.42	Please Require From Sales Person
裝箱重量 N.W / G.W	kg	2460 / 2950	3350 / 3940	Please Require From Sales Person
	lb	5423 / 6503	7385 / 8686	Please Require From Sales Person
<b>料架尺寸規格 / Magazine Table Dimensions</b>				
承載能力 Capacity	mm	Ø75 x 6000L x 13 支 pcs	Ø120 x 6000L x 8 支 pcs	Please Require From Sales Person
	in	Ø2.95 x 236.2L x 13 支 pcs	Ø4.72x 236.2L x 8 支 pcs	Please Require From Sales Person
料架尺寸 Size	mm	5700L x 1600W	5700L x 1500W	Please Require From Sales Person
	in	224.4L x 63W	224.4L x 59W	Please Require From Sales Person

### 標準配備 Standard Equipment

圓鋸片 Saw blade	1 片 pc
鋼刷輪 Wire brush	2 個 pcs
工作燈 Working lamp	1 組 set
工具箱 Tools with tool box	1 組 set
操作手冊 Instruction manual	1 本 copy

### 選擇配備 Optional Equipment

1. 清屑機 Auto chip conveyor.
2. 接長料架 Long cut-off pieces unloading table.
3. 整把料架 Bar stock reservoir and loader.
4. 平板工件用之鏈條式料架 Chain belt magazine table for flat work-piece.

# CS-180N/230N NEW EVOLUTION SERIES

NC 全自動切削高速圓鋸機

NC HIGH SPEED AUTOMATIC CARBIDE CIRCULAR SAW



## 規格表 Specifications

規格 / 機型 SPEC. / MODEL	UNIT	CS-180N	CS-230N
工作規格 Cutting Capacity	mm	● 70~180 ■ 70~130	● 75~230 ■ 75~160
	in	● 2.75~7.08 ■ 2.75~5.11	● 2.95~9.05 ■ 2.95~6.30
馬達馬力 Motor Output	hp	圓鋸驅動馬達 Blade -25/6P	圓鋸驅動馬達 Blade -40/6P
		油壓幫浦馬達 Hyd -5	油壓幫浦馬達 Hyd -5
		送料伺服馬達 Bar Feed Servo -5.9	送料伺服馬達 Servo -5.8 (feed)
		進刀伺服馬達 Servo Feedrate -3.8	進刀伺服馬達 Servo Feedrate -3.8 (cut)
鋸片尺寸 Blade Size	mm	Ø560 x Ø50 x T3.0	Ø750 x Ø80 x T3.8
	In	Ø22.04 x Ø1.96 x T0.118	Ø29.52 x Ø3.15 x T0.15
圓鋸迴轉速度 Blade Speed	rpm	40 → 100 變頻無段可調 Inverter Controlled Variable Speed	20 → 70 變頻無段可調 Inverter Controlled Variable Speed
		進刀方式 Blade Feed Cut	AC 伺服馬達+滾珠螺桿
送料方式 Bar Feed		AC 伺服馬達+滾珠螺桿	AC Servo Motor And Ball Screw
切斷長度 Auto Feed Length	mm	一次送料 Single Feed 20 ~ 600 二次送料以上 Multiple Feed 601 ~ 9999	一次送料 Single Feed 0.78 ~ 23.6 二次送料以上 Multiple Feed 23.6 ~ 393.6
	In	一次送料 Single Feed 0.78 ~ 23.6 二次送料以上 Multiple Feed 23.6 ~ 393.6	一次送料 Single Feed 0.78 ~ 23.6 二次送料以上 Multiple Feed 23.6 ~ 393.6
自動清屑機構 Auto Chip Conveyor		鏈條驅動(選配) Chain Belt Chip Conveyor (Optional)	鏈條驅動(選配) Chain Belt Chip Conveyor (Optional)
冷卻系統 Cooling System		空氣壓縮油霧 Air Compressed Oil Mist	空氣壓縮油霧 Air Compressed Oil Mist
裝箱尺寸 Packing Size (LxWxH)	mm	Please Require From Sales Person	
	ft	Please Require From Sales Person	
裝箱重量 N.W / G.W	kg	Please Require From Sales Person	
	lb	Please Require From Sales Person	

## 料架尺寸規格 / Magazine Table Dimensions

承載能力 Capacity	mm	Please Require From Sales Person
	in	Please Require From Sales Person
料架尺寸 Size	mm	Please Require From Sales Person
	in	Please Require From Sales Person

## 標準配備 Standard Equipment

圓鋸片 Saw blade	1 片 pc
鋼刷輪 Wire brush	2 個 pcs
工作燈 Working lamp	1 組 set
工具箱 Tools with tool box	1 組 set
操作手冊 Instruction manual	1 本 copy

## 選擇配備 Optional Equipment

1. 清屑機 Auto chip conveyor.
2. 接長料架 Long cut-off pieces unloading table.
3. 整把料架 Bar stock reservoir and loader.
4. 平板工件用之鏈條式料架 Chain belt magazine table for flat work-piece.

# CS-150S 全自動重切削高速圓鋸機

## NC HIGH SPEED HEAVY DUTY AUTOMATIC CARBIDE CIRCULAR SAW



### 規格表 Specifications

規格 / 機型 SPEC. / MODEL	CS-150S	
工作規格 Cutting Capacity	mm	● 50 ~ 150 (160) ■ 70 ~ 110 (120)
	in	● 1.97 ~ 5.91 (6.3) ■ 2.75 ~ 4.33 (4.72)
馬達馬力 Motor Output	HP	圓鋸驅動馬達 Blade-20/6P 油壓幫浦馬達 Hyd.-3 送料伺服馬達 Bar Feed Servo -1.73 進刀伺服馬達 Servo Feedrate -1.73
	KW	圓鋸驅動馬達 Blade-15/6P 油壓幫浦馬達 Hyd.-2.23 送料伺服馬達 Bar Feed Servo -1.3 進刀伺服馬達 Servo Feedrate -1.3
鋸片尺寸 Blade Size	mm	φ460 ( 480 ) X φ50 X T2.7
	in	φ18.1 ( 18.9 ) X φ1.96 X T 0.106
圓鋸迴轉速度 Blade Speed	rpm	60 - 90
進刀方式 Blade Feed Cut	.	AC 伺服馬達 + 滾珠螺桿 AC Servo Motor + Ball Screw
送料方式 Bar Feed	.	AC 伺服馬達 + 滾珠螺桿 AC Servo Motor + Ball Screw
切斷長度 Auto Feed Length	mm	一次送料 Single Feed 6~600 / 二次送料以上 Multiple Feed 600~9999
	in	一次送料 Single Feed 0.23~23.62 / 二次送料以上 Multiple Feed 23.62~393.6
自動清屑機構 Auto Chip Conveyor	.	鏈條驅動 ( 選配 ) Chain Belt Chip Conveyor (Opt.)
冷卻系統 Cooling System	.	空氣壓縮油霧 Air Compressed Oil Mist
裝箱尺寸 Packing Size (L X W X H)	mm	2580 X 2270 X 2260
	ft	8.46 X 7.45 X 7.41
裝箱重量 N.W. / G.W.	kg	3650 / 3800 ( 底板裝 With Pallets )
	lb	8030 / 8360 ( 底板裝 With Pallets )

### 標準配備 Standard Equipment

圓鋸片 Saw blade	1 片 pc
鋼刷輪 Wire brush	2 個 pcs
工作燈 Working lamp	1 組 set
工具箱 Tools with tool box	1 組 set
操作手冊 Instruction manual	1 本 copy

### 選擇配備 Optional Equipment

1. 清屑機 Auto chip conveyor.
2. 接長料架 Long cut-off pieces unloading table.
3. 整把料架 Bar stock reservoir and loader.
4. 平板工件用之鏈條式料架 Chain belt magazine table for flat work-piece.



# CS-75F/120F

全自動重切削高速圓鋸機 (切非鐵金屬)

NC HIGH SPEED HEAVY DUTY AUTOMATIC CARBIDE CIRCULAR SAW  
(NONFERROUS METAL CUTTING)



## 規格表 Specifications

規格 / 機型 SPEC. / MODEL		CS-75F	CS-120F
工作規格 Cutting Capacity	mm in	● 10 ~ 75 ■ 15 ~ 60 ● 0.39 ~ 2.95 ■ 0.6 ~ 2.36	● 20 ~ 120 ■ 20 ~ 85 ● 0.79 ~ 4.72 ■ 0.79 ~ 3.35
馬達馬力 Motor Output	HP	圓鋸驅動馬達 Blade 10/2P 油壓幫浦馬達 Hydraulic Pump 2 送料伺服馬達 Bar feed Servo 0.65 進刀伺服馬達 Servo Feedrate 1.13 吸屑集塵機 Vacuum Chip Collector 1 (Opt.) 吹屑鼓風機 Debris Blower 0.5	油圓鋸驅動馬達 Blade 20/2P 油壓幫浦馬達 Hydraulic Pump 3 送料伺服馬達 Bar Feed Servo 1.74 進刀伺服馬達 Servo Feedrate 2.41 吸屑集塵機 Vacuum Chip Collector 3 (Opt.) 吹屑鼓風機 Debris Blower 0.5
	KW	圓鋸驅動馬達 Blade 7.5/2P 油壓幫浦馬達 Hydraulic Pump 1.5 送料伺服馬達 Bar feed Servo 0.5 進刀伺服馬達 Servo Feedrate 0.85 吸屑集塵機 Vacuum Chip Collector 0.75 (Opt.) 吹屑鼓風機 Debris Blower 0.38	圓鋸驅動馬達 Blade 15/2P 油壓幫浦馬達 Hydraulic Pump 2.25 送料伺服馬達 Bar feed Servo 1.3 進刀伺服馬達 Servo Feedrate 1.8 吸屑集塵機 Vacuum Chip Collector 2.25 (Opt.) 吹屑鼓風機 Debris Blower 0.38
鋸片尺寸 Blade Size	mm in	φ305 X φ25.4 X T2.6 φ12 X φ1 X T0.102	φ405 X φ25.4 X T3.2 φ15.94 X φ1 X T0.126
圓鋸迴轉速度 Blade Speed	rpm	3000 - 5500	
進刀方式 Blade Feed Cut	.	AC 伺服馬達 + 滾珠螺桿 AC Servo Motor + Ball Screw	
送料方式 Bar Feed	.	AC 伺服馬達 + 滾珠螺桿 AC Servo Motor + Ball Screw	
切斷長度 Auto Feed Length	mm	一次送料 Single Feed 6~600 / 二次送料以上 Multiple Feed 600~9999	
	in	一次送料 Single Feed 0.23~23.62 / 二次送料以上 Multiple Feed 23.62~393.6	
自動清屑機構 Auto Chip Conveyor	.	鏈條驅動 + 吸屑集塵機 (選配) Chain Belt Chip Conveyor + Vacuum Chip Collector (Opt.)	
冷卻系統 Cooling System	.	空氣壓縮油霧 Air Compressed Oil Mist	
裝箱尺寸 Packing Size (L X W X H)	mm	2290 X 2240 X 2130	2290 X 3050 X 2150
	ft	7.51 X 7.35 X 6.99	7.51 X 10.01 X 7.05
裝箱重量 N.W. / G.W.	kg	2300 / 2450 (底板裝 With Pallets)	3350 / 3940 (底板裝 With Pallets)
	lb	5060 / 5390 (底板裝 With Pallets)	7385 / 8686 (底板裝 With Pallets)

### 標準配備 Standard Equipment

圓鋸片 Saw blade	1 片 pc
操作手冊 Instruction manual	1 本 copy
工作燈 Working lamp	1 組 set
工具箱 Tools with tool box	1 組 set

### 選擇配備 Optional Equipment

1. 清屑機及吸屑機 Auto chip conveyor and vacuum chip collector.
2. 接長料架 Long cut-off pieces unloading table.
3. 整把料架 Bar stock reservoir and loader.
4. 平板工件用之鏈條式料架 Chain belt magazine table for flat work-piece.

# CS-150F 全自動重切削高速圓鋸機 (切非鐵金屬)

## NC HIGH SPEED HEAVY DUTY AUTOMATIC CARBIDE CIRCULAR SAW (NONFERROUS METAL CUTTING)



### 規格表 Specifications

規格 / 機型 SPEC. / MODEL	CS-150F	
工作規格 Cutting Capacity	mm	● 50 ~ 150 ■ 70 ~ 110
	in	● 1.97 ~ 5.91 ■ 2.75 ~ 4.33
馬達馬力 Motor Output	HP	圓鋸驅動馬達 Blade 20/4P 油壓幫浦馬達 Hydraulic Pump 3 送料伺服馬達 Bar feed Servo 1.73 進刀伺服馬達 Servo Feedrate 1.73 吸屑集塵機 Vacuum Chip Collector 5 (Opt.) 吹屑鼓風機 Debris Blower 0.5
	KW	圓鋸驅動馬達 Blade 15/4P 油壓幫浦馬達 Hydraulic Pump 2.23 送料伺服馬達 Bar feed Servo 1.3 進刀伺服馬達 Servo Feedrate 1.3 吸屑集塵機 Vacuum Chip Collector 3.75(Opt.) 吹屑鼓風機 Debris Blower 0.38
鋸片尺寸 Blade Size	mm	φ455 X φ25.4 X T3.4
	in	φ17.9 X φ1 X T0.133
圓鋸迴轉速度 Blade Speed	rpm	1000 - 2100
進刀方式 Blade Feed Cut	.	AC 伺服馬達 + 滾珠螺桿 AC Servo Motor + Ball Screw
送料方式 Bar Feed	.	AC 伺服馬達 + 滾珠螺桿 AC Servo Motor + Ball Screw
切斷長度 Auto Feed Length	mm	一次送料 Single Feed 6~600 / 二次送料以上 Multiple Feed 600~9999
	in	一次送料 Single Feed 0.23~23.62 / 二次送料以上 Multiple Feed 23.62~393.6
自動清屑機構 Auto Chip Conveyor	.	鏈條驅動 + 吸屑集塵機 (選配) Chain Belt Chip Conveyor+ Vacuum Chip Collector (Opt.)
冷卻系統 Cooling System	.	空氣壓縮油霧 Air Compressed Oil Mist
裝箱尺寸 Packing Size (L X W X H)	mm	2580 X 2270 X 2260
	ft	8.46 X 7.45 X 7.41
裝箱重量 N.W. / G.W.	kg	3520 / 3670 (底板裝 With Pallets)
	lb	7744 / 8074 (底板裝 With Pallets)

### 標準配備 Standard Equipment

圓鋸片 Saw blade	1 片 pc
操作手冊 Instruction manual	1 本 copy
工作燈 Working lamp	1 組 set
工具箱 Tools with tool box	1 組 set

### 選擇配備 Optional Equipment

1. 清屑機及吸屑機 Auto chip conveyor and vacuum chip collector.
2. 接長料架 Long cut-off pieces unloading table.
3. 整把料架 Bar stock reservoir and loader.
4. 平板工件用之鏈條式料架 Chain belt magazine table for flat work-piece.

## 選擇配備 OPTIONAL EQUIPMENT

### 清潔鋸屑或油霧 CHIPS/OIL REMOVING AND CLEANING



**自動清屑機構**  
機台處於自動循環切削時，自動清屑機構即能發揮最佳效率。

**AUTO CHIP CONVEYOR**  
Conveys chips into waste tank for efficient chip cleaning during automatic cutting cycle.



**鼓風除屑機**  
(僅適用於 CS-F 機種)  
非鐵合金切削，如鋁合金工件。快速切削時大量碎屑飛濺搭配本機可快速清屑。

**VACUUM CHIP COLLECTOR**  
(Optional only for CS-F models)  
Vacuum chip collector is suitable for nonferrous metal cutting such as aluminum alloy. It collects chips produced from fast cutting.



**油霧分離機**  
外型輕巧效率高，採離心式過濾，是最有效的油霧收集方式，使用此裝置可達到環境品質良好並顧及操作者健康和安全的的需求。

**MIST FILTER**  
Compact, highly efficient, with the most effective way of collecting oil mist, centrifugal filtration. The device satisfies the demand of environment friendly production and shows the concern for the operators' health and safety.

### 儲料架 / 進料架 / 出料架 LOADING AND UNLOADING

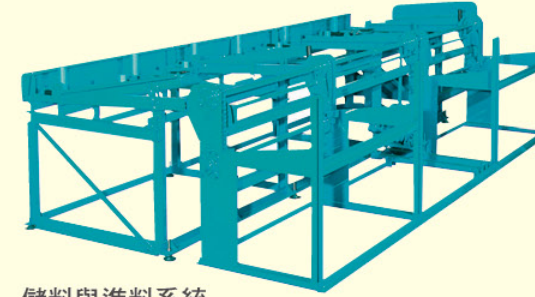

**儲料與進料系統**  
可放置大量待切材料，適時自動補充工件於送料架上。自動化節省人力。\*可依個別需求客製化

**BAR STOCK RESERVOIR AND LOADER**  
Designed especially for stock work-piece. It delivers work-piece to magazine table automatically, which saves human power greatly. \* Customization available.

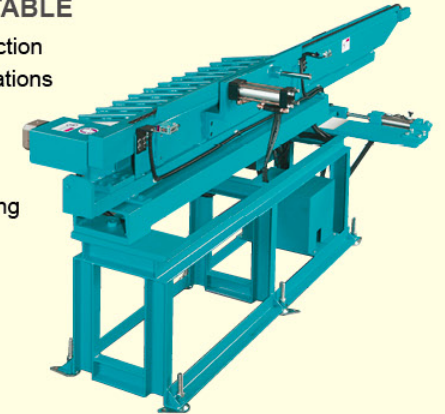

**鍊條或滾輪式出料架**  
依自動化生產需求，可搭配儲料桶或機械手臂使用。

**UNLOADING TABLE**  
For various production demands, specifications are customized. Robotic arms are available for automatic unloading and unloading.

### 薄鋸片 LESS MATERIAL CONSUMPTIONS

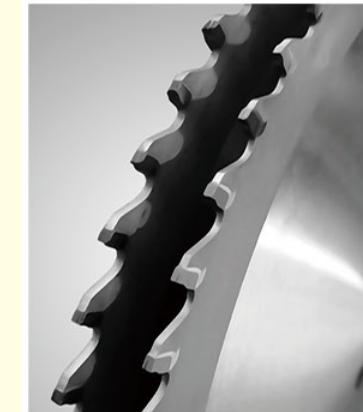

**超薄鋸片**  
超薄鋸片比一般鋸片厚度減少 0.25mm，可大量減少碎屑，進一步達成省材料，節省能源之功效。

**SUPER-THIN BLADE**  
It is 0.25mm thinner than normal one, which reduces material wastes and lowers cutting costs.



MEMO

---

MEMO

---