



S 35 (M, ME)

Drill head

The drill head is adjustable 360° around the column and can be raised and lowered.

Gear box

The gear box is built according to our experienced methods for highest possible torque. Helical gears combined with steel gears against reinforced fiber gears in the main gear box ensure higher operating efficiency, a more powerful drive mechanism and smooth operation. The noise level and maintenance of the gear box is reduced to a minimum. The eight (8) spindle speeds are easily selected by changing two handles.

Power feed (M)

The power feed of model S 35 M is provided with an automatic overload protection device, which starts when the drill pressure becomes too high. When overload diminishes, the feed is automatically re-engaged. When the set drill depth is reached, the spindle will automatically return to the starting point. The feed can also be interrupted manually.

Automatic feed (ME)

The start/stop function of the automatic feed is fitted with electromagnetic clutch, giving push button operation. The push buttons are situated at the top of the three feed levers. Hand and automatic reversing for tapping are standard.

Table

The machine is fitted with a high quality cast iron rectangular table 500 x 400 mm, complete with T-slots and coolant channel.

Spindle

The spindle is made from steel, with the lower spindle bearing being located as near to the lower part of the spindle as possible, ensuring greater precision and rigidity even in milling operations. It is further adjustable by the journals in the bearings, which guarantee very small tolerances. The spindle is counterbalanced by a tension spring and the spindle return can be adjusted depending on the weight of the tool. It can be locked when carrying out milling operations.

Column

The column is constructed of steel, which ensures extra rigidity of the machine, giving accurate precision and a minimum deviation from the stipulated angle between the drill and the table.

Base plate

The base plate has a machined surface, complete with T-slots and coolant channel.

Safety

The machine is supplied with a thermal overload switch, no-volt release and emergency stop.

Options (selection)

Coolant complete with tubes, machine light halogen, chuck guard, micro switch for chuck guard, coordinate table 450 x 242 mm, coordinate table 584 x 242 mm (with or without automatic feed), threaded spindle nose with locking nut, automatic reversing unit for tapping, foot operated reversing switch, foot operated start switch, tool package MT 4



S 35 ME



Technical data - S 35 (M, ME)

Drilling capacity	Ø 35 mm
Quill movement	150 mm
Tapping capacity (steel, cast iron)	M 18 / M 22
Morse taper	MK / MT 4
Motor power (50 Hz)	1,40 kW / 2,00 kW
Motor power (60 Hz)	1,60 kW / 2,20 kW
Spindle speed (50 Hz)	75-160-265-440-535-890-1490-3010
Spindle speed (60 Hz)	90-190-320-640-530-1060-1790-3610
Feed speed (mm/inch per rev.)	0,10 / 0,004 - 0,15 / 0,006 - 0,22 / 0,009 - 0,30 / 0,012
Size of table	500 x 400 mm
Net weight	290 kg

Drill guard is standard within CE area.

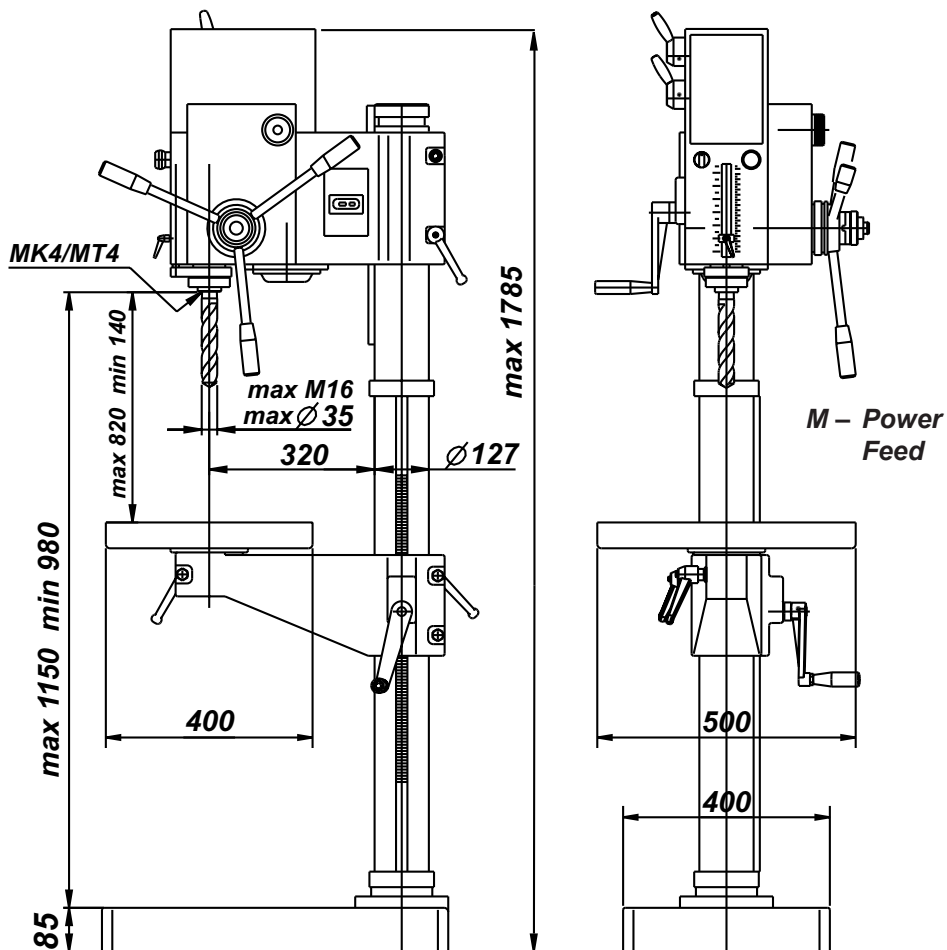

Machinery Scandinavia AB

570 83 Rosenfors, Sweden
 tel +46 495 49700, fax +46 495 20730
 Email: sales@mscab.se
 URL: www.strandsmachinery.com

