



# S 40 (M, ME)

## Drill head

The drill head is fixed and is available with or without automatic spindle feed.

## Gear box

The gear box is built according to our experienced methods for highest possible torque. Helical gears combined with steel gears against reinforced fiber gears in the main gear box ensure higher operating efficiency, a more powerful drive mechanism and smooth operation. The noise level and maintenance on the gear box is reduced to a minimum.

## Power feed (M)

The power feed is provided with an automatic overload protection device, which starts when the drill pressure becomes too high. When overload diminishes, the feed is automatically re-engaged. When the set drill depth is reached, the spindle will automatically return to the starting point. The feed can also be interrupted manually.

## Automatic feed (ME)

The start/stop function of the automatic feed is fitted with electromagnetic clutch, giving push button operation. The push buttons are situated at the top of the three feed levers. Hand and automatic reversing for tapping are standard.

## Table

The machine is fitted with a fixed table 500 x 400 mm as standard, mounted on a rigid arm and adjustable 360° around the column. There is an adjustable crank on the front side of the table arm for elevating and lowering the table to the correct working height.

## Spindle

The spindle is made from steel, with the lower spindle roller bearing being located as near to the lower part of the spindle as possible, ensuring greater precision and rigidity, even in milling operations. It is further adjustable by the journals in the bearings, which guarantee very small tolerances. The spindle is fitted with a counterbalanced tension spring and is adjustable depending on the weight of the tool.

## Column

The column is constructed of steel, which ensures extra rigidity of the machine, giving accurate precision and a minimum deviation from the stipulated angle between the drill and the table.

## Safety

The machine is equipped with thermal overload switch, no-volt release and emergency stop.

## Options (selection)

Coolant complete with tubes, machine light halogen, micro switch for chuck guard, rotary device for table 400 x 500 mm, rectangular table 600 x 500 mm, coordinate table 450 x 242 mm, coordinate table 584 x 242 mm (with or without automatic feed), coordinate table 650 x 270 mm (with or without longitudinal feed), tool package MT 4, threaded spindle nose with locking nut, flanged quill with double return spring for multi-spindle drill head, automatic reversing unit for tapping, foot operated start switch, high spindle speeds (180 - 3000 rpm), low spindle speeds (60 - 980 rpm), telescopic chuck guard



ME start/stop autom. feed  
right / left reverse

S 40 M



## Technical data - S 40 (M, ME)

Drilling capacity	Ø 40 mm
Quill movement	190 mm
Tapping capacity – steel	M 24
Tapping capacity – cast iron	M 28
Morse taper	MK / MT 4
Motor power (50 Hz / 60 Hz)	2,20 kW / 2,60 kW
Spindle speed (50 Hz)	90-135-200-300-440-670-980-1500
Spindle speed (60 Hz)	108-162-240-360-528-805-1175-1800
Feed speed (mm/inch per rev.)	0,10 / 0,004 - 0,16 / 0,0064 - 0,24 / 0,01 - 0,33 / 0,013
Net weight S 40 / S 40 M, ME	310 kg / 320 kg
Size of table	500 x 400 mm

Drill guard is standard within CE area.

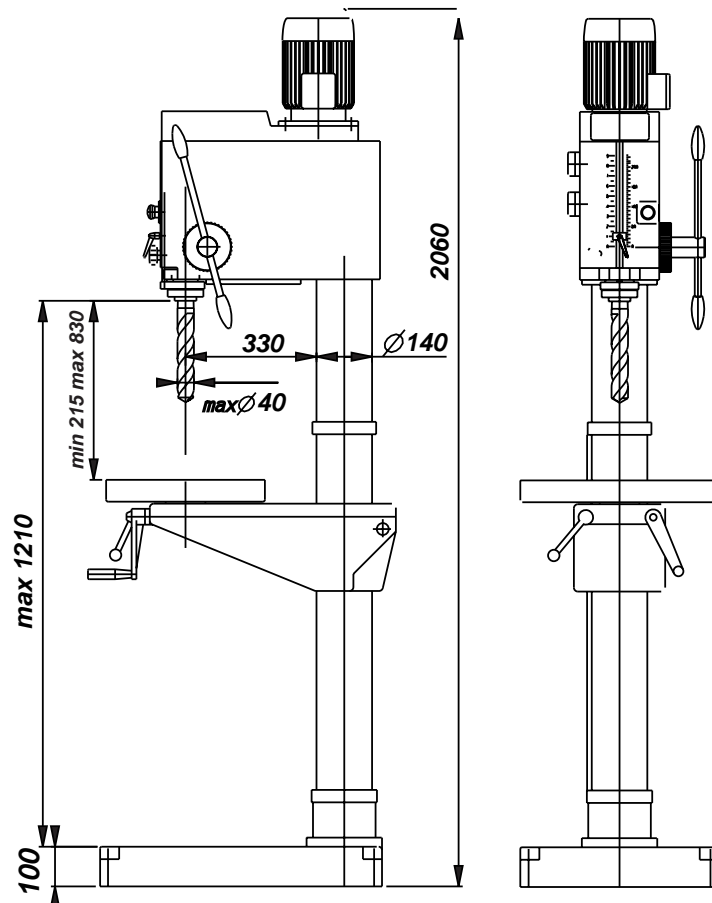

### Machinery Scandinavia AB

570 83 Rosenfors, Sweden  
tel +46 495 49700, fax +46 495 20730  
Email: [sales@mscab.se](mailto:sales@mscab.se)  
URL: [www.mscab.se](http://www.mscab.se)

