

MODEL = 2S/2VS

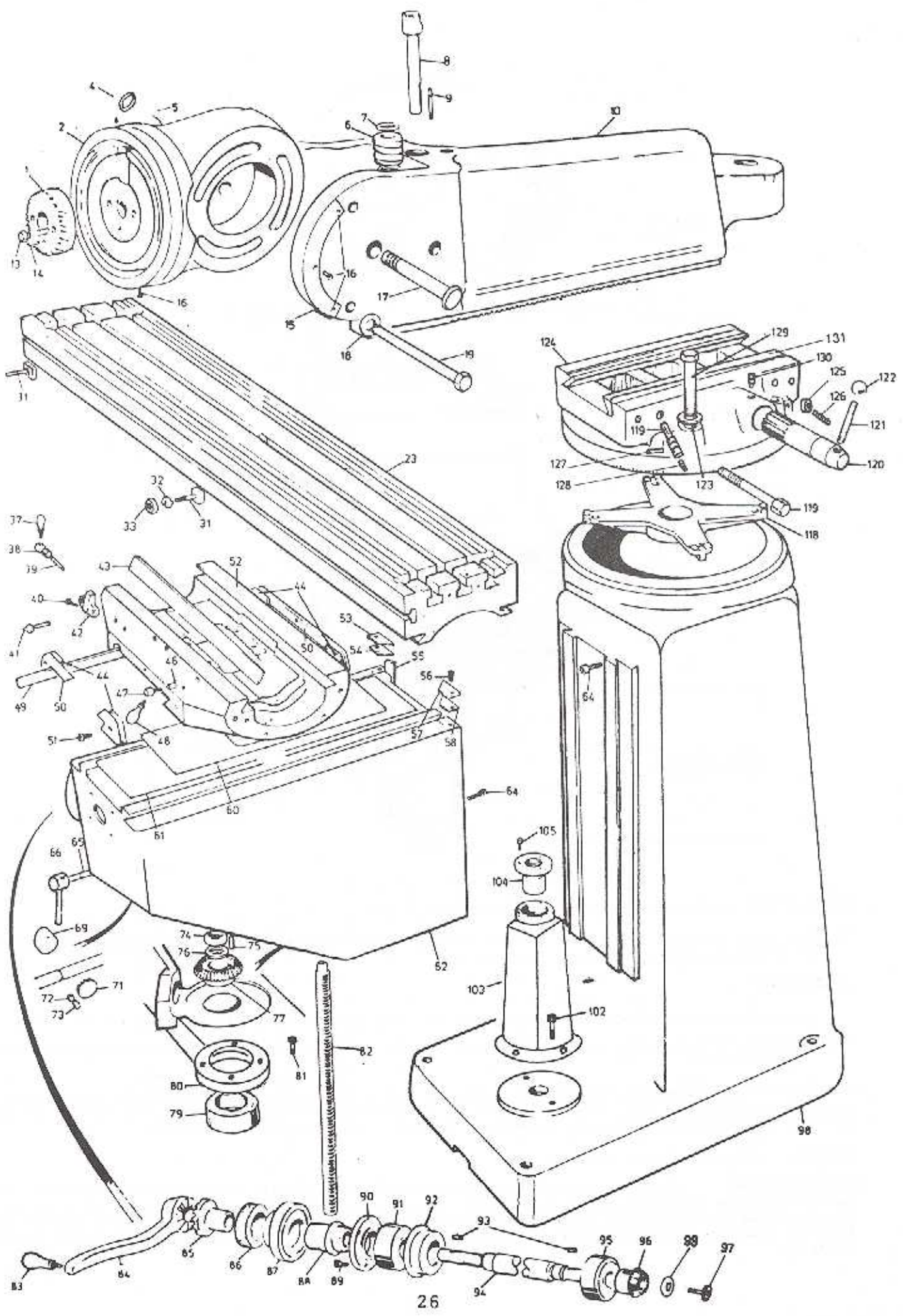

## BASIC MACHINE

ITEM NO.	PARTS NO.	DESCRIPTION	ITEM NO.	PARTS NO.	DESCRIPTION
1	5033	Quill Housing ADJ. Gear	69	4001-1	Knee Lock Plunger
2	5019	Ram Adapter	71	4045	Knee Binder Plug (Plastic)
4	5027	Nut	72	4049	Dog Point Set Screw
6	5020	Vertical Adjusting Worm	73	4049	Set Screw
7	5022	Worm Thrust Washer (2 Req.)	74	4023	Jam Nut
8	5021	Vertical Adjusting Worm Shaft	75	4020	Key
9	5023	Worm Key	76	4022	Washer
10	5018	Ram	77	4019	Bevel Gear
13	5035	Socket Cap Screw (2 Req.)	79	4040	Sealed Ball Bearing
14	5034	Roll Dowel Pin	80	4039	Bearing Retainer Ring
15	5043	Angle Plate	81	4041	Socket Head Cap Screw
16	5032	Round HD Drive Screw (5 Req.)	82	4021	Elevating Screw Assembly
17	5026	Adapter Pivot Pin	83	4003	Handle
18	5029	Chamfered & Hardened Washer (7 Req.)	84	4002	Elevating Crank
19	5028	Adapter Locking Bolt (3 Req.)	85	4013	Gearshaft Clutch Insert
23	2001	Table 42" or 48"	86	2016	Dial Lock Nut
			87	4010	Dial with 100 Graduations
			88	4011	Dial Holder
31	2031	Stop Piece T-Bolt (3 Req.)	89	4009	Socket Head Cap Screw
32	2030	Table Stop Piece (2 Req.)	90	2011	Bearing Retaining Ring
33	2032	Hex Nut (3 Req.)	91	2008	Grease Sealed Bearing
37	3031	Table Lock Bolt Handle	92	4006	Bearing Cap
38	3030	Saddle Lock Bolt	93	4015	Key
39	3032	Saddle Lock Plunger	94	4017	Elevating Shaft for 12" Knee
40	3036	Socket HD Cap Screw (2 Req.)	95	2008	Grease Sealed Bearing
41	3028	Gib Adjusting Screw (3 Req.)	96	4014	Bevel Pinion
42	3035	Table Stop Bracket	97	4042	Set Screw
43	3026	Saddle/Table Gib	98	1001	Column
44	3037	Felt Wipers (4 Req.)	99	4017-1	Washer
46	3029	Table Lock Plunger	102	4027	Socket Head Cap Screw
47	3030	Table Lock Bolt	103	4026	Pedestal
48	3031	Table Lock Bolt Handle	104	4024	Elevating Screw Nut
49	3027	Saddle/Knee Gib	105	4025	Socket Head Cap Screw
50	3037-2	Saddle Knee Wiper Plate (4 Req.)	118	5003	Spider
51	3038	Oval Head Screw (8 Req.)	119	5010	Ram Lock Stud
52	3001	Saddle	120	5012	Ram Pinion
53	4028-2	Left Hand Column Wiper Holder	121	5013	Ram Pinion Handle
54	4028-1	Knee Wiper Felt	122	5014	Plastic Ball
55	4038	Knee/Column Gib	123	5005	Chamfered x Hardened Washer
56	4029	Allen Cap Screw (2 Req.)	124	5001	Turret
57	4028-3	Right Hand Column Wiper Holder	125	5007-1	Gib Screw Nut
58	4028	Knee Wiper Felt	126	5007	Gib Screw
60	3040	Chip Guards - Upper	127	5009	Lock Bar
61	3039	Chip Guards - Lower	128	5009-1	Screw
62	4001	Knee 12"	129	5004	Locking Bolt
64	1001-1	Stop Screw	130	5015	Ram Pinion Screw
65	4048	Knee Lock Shaft Assembly	131	5002	Ram/Turret Gib

MODEL: 2VS, 3VH, 4VS, 5VH, 2S, 3H, 4S, 5H

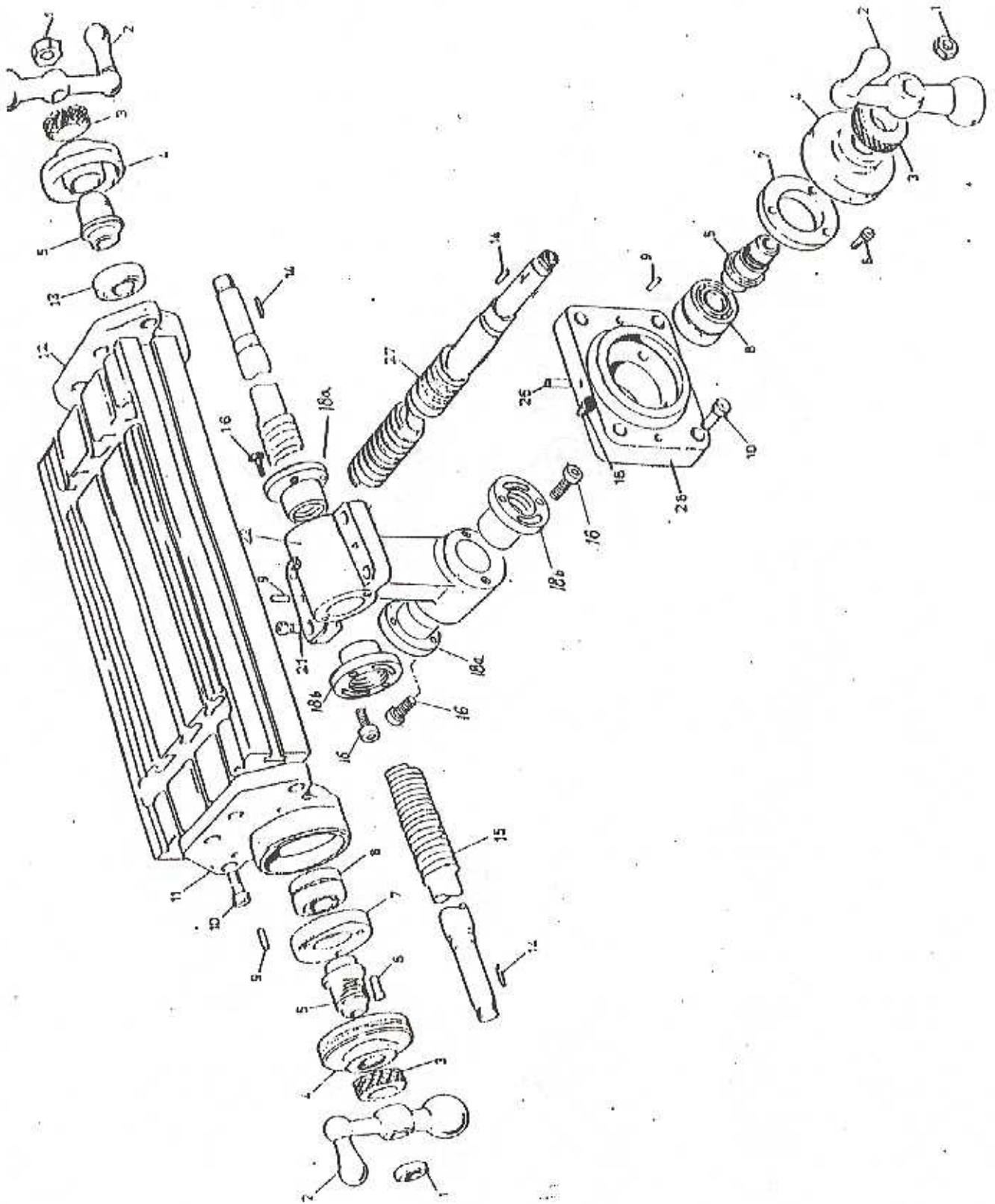

## LEADSCREW ASSEMBLY

ITEM NO.	PARTS NO.	DESCRIPTION
1	2004	Jam Nut (3 Req.)
2	2018	Ball Crank Handle (3 Req.)
3	2004	Dial Lock Nut (3 Req.)
4	2012	Dial with 200 Graduations (3 Req.)
5	2014	Dial Holder (3 Req.)
6	2036	Socket Cap Screw (6 Req.)
7	2011	Bearing Retainer Ring (2 Req.)
8	2008	Grease Sealed Ball Bearings (2 Req.)
9	2027	Roll Pin (10 Req.)
10	2026	Socket Cap Screw (12 Req.)
11	2006	Left Bearing Bracket
12	2006	Right Bearing Bracket
13	2008	Grease Seal Ball Bearing
14	2003	Key (3 Req.)
15	2002	Longitudinal Feed Screw 42" or 48"
16	3021	Socket Cap Screw (8 Req.)
17	3019	Cross Feed Nut Retaining Plate (2 Req.)
18	3020	Longitudinal Feed Nut
20	3041	Key (2 Req.)
21	3024	Socket Cap Screw (8 Req.)
22	3023	Longitudinal Feed Nut Bracket
23	3022	Cross Feed Nut Bracket
24	3020	Cross Feed Nut
26	3005-1	Stop Screw
27	3002	Cross Feed Screw for 12" Knee
28	3005	Cross Feed Bearing Bracket

# MODEL = 2S/2VS

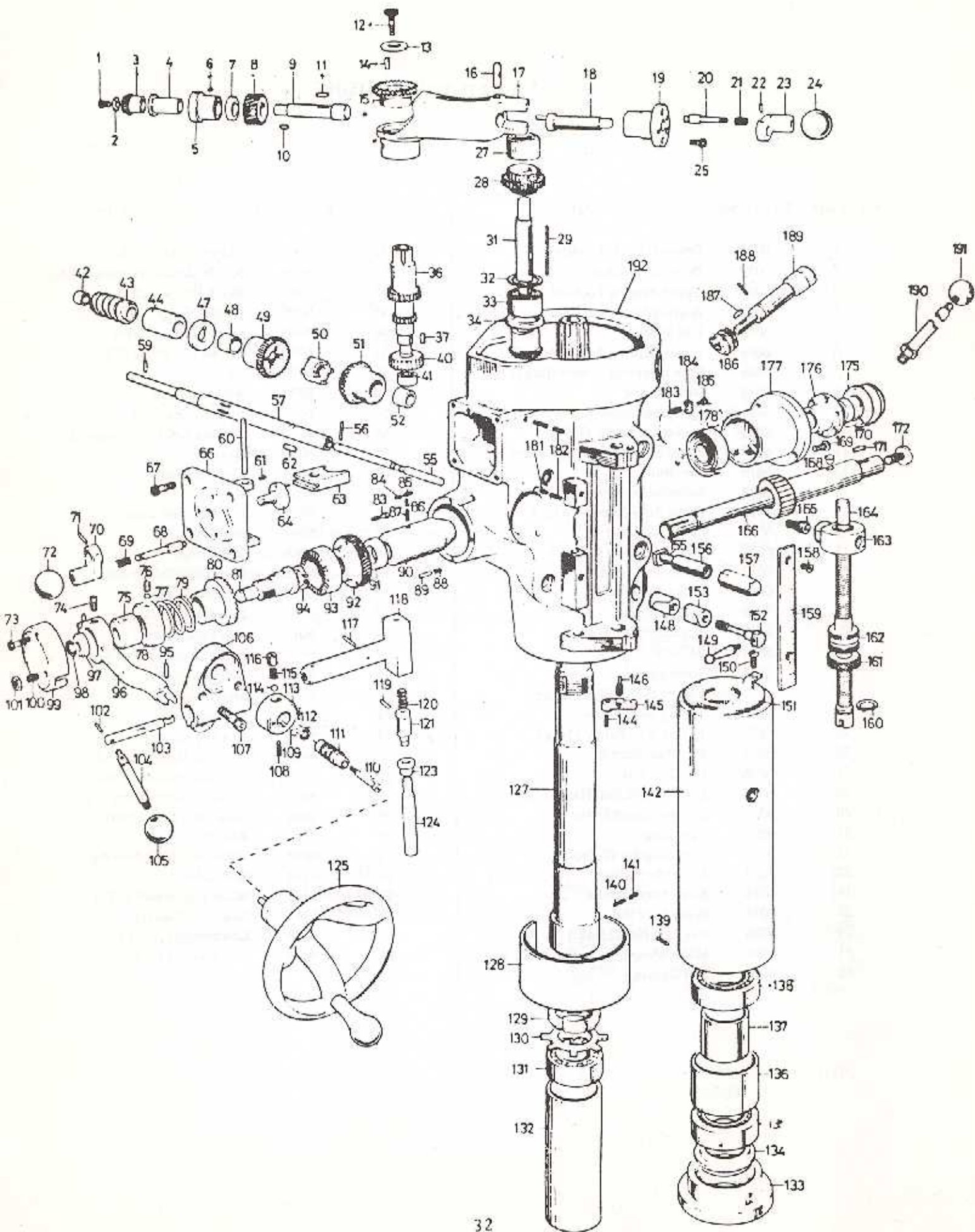

## J HEAD

ITEM NO.	PARTS NO.	DESCRIPTION	ITEM NO.	PARTS NO.	DESCRIPTION
1	6141	RD. HD. Screw	61	6164	KP. Set Screw
2	6140	Bevel Pinion Washer	62	6230	Key
3	6139	Feed Bevel Pinion	63	6162	Feed Gear Shift Fork
4	6138	Feed Worm Gear Shaft Sleeve	64	6166	Cluster Gear Shift Crank
5	6137	Worm Cradle Bushing	66	6161	Cluster Gear Cover
6	6123	Setscrew	67	6165	Cap Screw (4 Req.)
7	6136	Worm Gear Spacer (4 Req.)	68	6169	Gear Shift Plunger
8	6134	Feed Drive Worm Gear	69	6170	Compression Spring
9	6133	Feed Drive Worm Gear Shaft	70	6168	Shift Crank
10	6142	Worm Shaft Key	71	6167	Roll Pin
11	6135	Key	72	6171	Black Plastic Ball
12	6150	Locknut	73	6206	Cap Screw (2 Req.)
13	6149	Washer	74	6202	Clutch Ring Pin (2 Req.)
14	6147	Cluster Gear Key	75	6200	Clutch Ring
15	6148	Feed Reverse Bevel Gear	76	6199	Socket Set Screw
16	6122	Feed Engage Pin	77	6199-1	Brass Plug
17	6121	Worm Gear Cradle	78	6198	Overload Clutch Locknut
18	6126	Worm Gear Cradle Throw-out	79	6197	Safety Clutch Spring
19	6125	Shift Sleeve	80	6194	Overload Clutch
20	6169	Gearshift Plunger	81	6195	Overload Clutch Sleeve
21	6170	Compression Spring	82	6190	Single Spring Washer (3 Req.)
22	6128	Roll Pin	83	6189	Round Head Screw (3 Req.)
23	6168	Shift Crank	84	6228	Mock-it Lockscrew
24	6131	Black Plastic Ball	85	6228	Socket Set Screw
25	6132	Cap Screw (3 Req.)	86	6246	Lockscrew
27	6157	Cluster Gear Shaft Upper Bearing	87	6246-1	Socket Set Screw
28	6153	Cluster Gears Assembly	88	6191	Compression Spring
29	6160	Cluster Gear Key	89	6193	Overload Clutch Lever Spring Plunger
31	6151	Cluster Gear Shaft	90	6186	Quill Pinion Shaft Bushing
32	6158	Snap Ring	91	6190	Pinion Shaft Worm Gear Spacer
33	6156	Bevel Gear Bearing	92	6187	Overload Clutch Worm Gear
34	6159	Bevel Gear Thrust Spacer	93	6188	Overload Clutch Ring
35	6151	Feed Reverse Bevel Pinion	94	6188-1	Snap Ring
36	6143	Feed Driving Gear	95	6236-1	Dowel Pin
37	6145	Key	96	6203	Overload Clutch Trip Lever
38	6143	Cluster Gear Input Shaft	97	6201	Overload Clutch Washer
40	6144	Feed Drive Gear	98	6195-1	Snap Ring
41	6252	Needle Bearing	99	6205	Clutch Arm Cover
42	6227	Bushing	100	6207	Socket Set Screw
43	6225	Worm	101	6208	Chem Blacked Locknut
44	6224	Feed Worm Shaft Bushing	103	6239	Cam Rod
47	6223	Feed Worm Shaft Thrust Washer	104	6234	Trip Handle
48	6220	Bushing	105	6233	Black Plastic Ball
49	6220	Feed Reverse Bevel Gear	106	6231	Feed Trip Bracket
50	6222	Feed Reverse Clutch	107	6232	Cap Screw (2 Req.)
51	6220	Feed Reverse Bevel Gear	108	6219	Socket Set Screw
52	6220	Bushing	109	6229	Key
55	6216	Reverse Clutch Rod	110	6214	Feed Reverse Knob Stud
56	6217	Roll Pin	111	6213	Reverse Knob
57	6209	Feed Worm Shaft	112	6215	Snap Ring
59	6226	Pin	113	6218	Handwheel Clutch
60	6163	Feed Shift Rod	114	6255	Steel Ball

## J HEAD (CONTINUED)

ITEM NO.	PARTS NO.	DESCRIPTION	ITEM NO.	PARTS NO.	DESCRIPTION
115	6219-2	Compression Spring	158	6244	Chem Blacked RD.HD. Screws (2 Req.)
116	6219-1	Handwheel Clutch Spring Screw	159	6243	Micrometer Scale
117	6237	Roll Pin	160	6115	Snap Ring
118	6236	Cam Rod Sleeve Assy.	161	6108	Quill Micro-stop Nut
119	6241	Roll Pin	162	6107	Micrometer Nut
120	6242	Compression Spring	163	6105	Quill Stop Knob
121	6240	Trip Plunger	164	6104	Quill Stop Micro-screw
123	6118-1	Trip Plunger Bushing	165	6106	Screw
124	6118	Feed Trip Plunger	166	6172	Quill Pinion Shaft
125	6210	Handwheel	168	6185	Spring Pin
127	6084	Spindle	169	6180-1	RD. Head Screw (2 Req.)
128	6086	Quill Skirt	170	6179	Roll Pin
129	6090	Locknut	171	6184	Key
130	6091	Lockwasher	172	6183	Pinion Shaft Hub Screw
131	6092	Bearing	173	6176	Steel Ball
132	6094	Sleeve	174	6175	Compression Spring
133	6098	Nose-piece	175	6178	Rack Feed Handle Hub
134	6097	Spindle Dirt Shield	176	6182	Pinion Shaft Hub Sleeve
135	6093	Bearing	177	6180	Spring Cover
136	6095	(Bearing Spacer—Large)	178	6181	Clock Spring (Clock Spring Assy.)
137	6096	(Bearing Spacer—Small)			
138	6093	Bearing	180	6172	Quill Pinion
140	6253	Special Socket Set Screw	181	6246-1	Socket Set Screw
141	6254	Collet Alignment Screw	182	6246	Lockscrew
142	6085	Quill	183	6110	Reverse Trip Ball Lever
144	6113	Socket Set Screw	184	6109	Feed Reverse Trip Plunger
145	6111	Feed Trip Lever	185	6114	Reverse Trip Ball Lever Screw
146	6112	Trip Lever Pin	186	5039	Worm Gear
148	6116	Quill Lock Sleeve	187	5041	Key
149	6119	Lock Handle	188	5042	Socket Set Screw
151	6088	Felt Washer	189	5040	ADJ Worm Shaft
152	6117	Quick Lock Bolt	190	6174	Pinion Shaft Hub Handle
153	6116	Quill Lock Sleeve Tapped	191	6173	Black Plastic Bail Handles
155	5036	T-Bolt Assy.	192	6101	Quill Housing
156	6120	Lower Clamping Bolt Spacer (2 Req.)			
157	5038	Locknut			

MODEL = 2VS

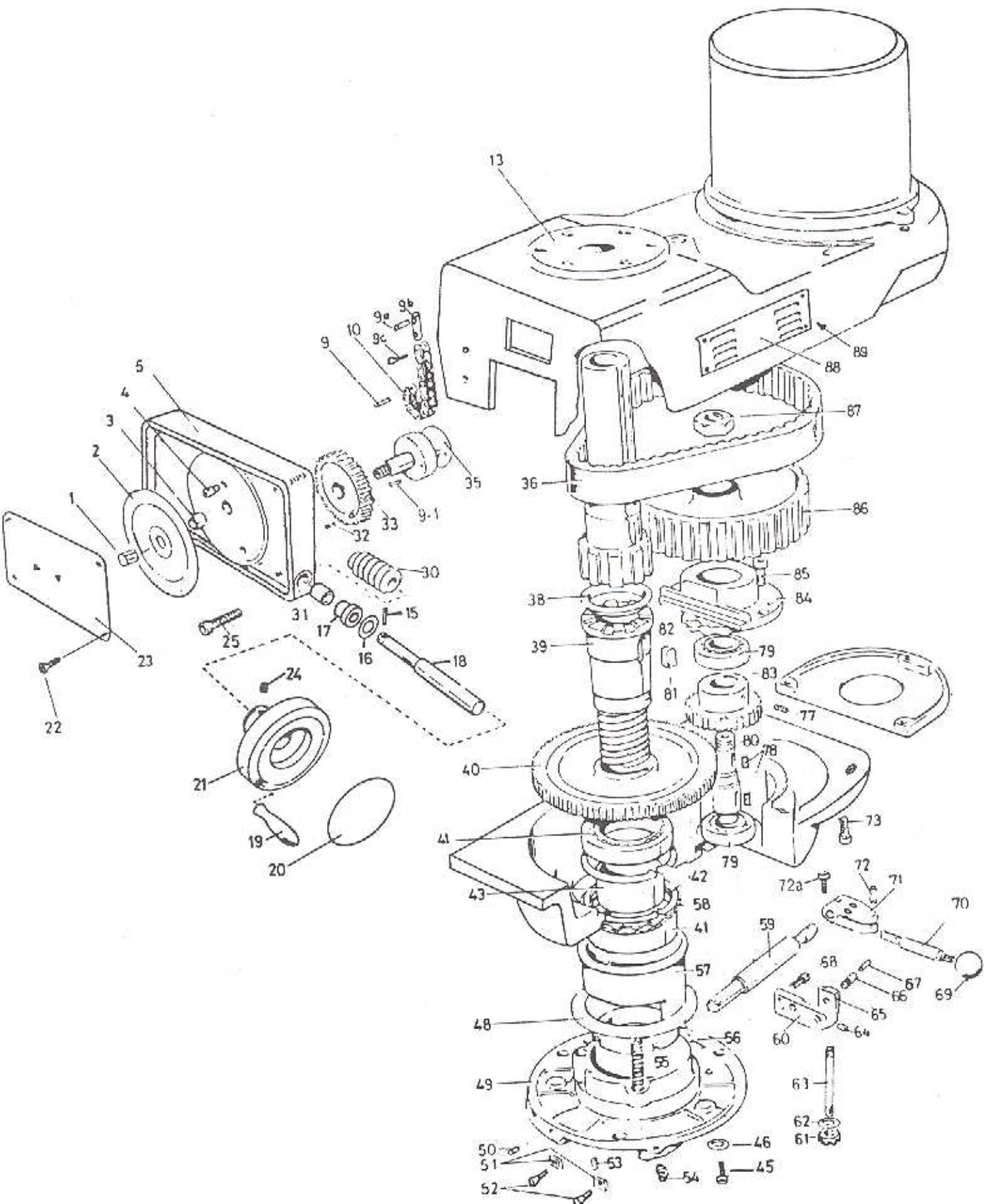



## 2J HEAD TOP HOUSING

ITEM NO.	DESCRIPTION	ITEM NO.	DESCRIPTION
1	Hex Cap Nut	47	Hex Jam Nut—Finished HDN. (3 Req.)
2	Vari-Speed Dial	48	Ball Bearing Gear Sleeve Washer
3	Bronze Bearing	49	Fixed Clutch Bracket
4	Full Dog Socket Set Screw	50	Socket Set Screw
5	Speed Changer Housing	51	Guide for Clutch Bracket
6	Speed Changer Chip Shield	52	Flat HD Socket Cap Screw (2 Req.)
7	Machine Screws (2 Req.)	53	Dowel Pin
9	Roll Pin	54	Oil Cup
9-1	Roll Pin	55	Compression Spring (3 Req.)
9a	Roll Pin	56	Bearing Locknut
9b	Speed Change Stud	57	Bearing Sleeve
9c	Cotter Pin	58	Wave Spring Washer
10	Speed Changer Chain	59	Bull Gear Shift Pinion
11	Drum Switch	60	HI-LOW Detent Plate
13	Top Bearing Cap	61	Hex Nut (3 Req.)
14	Soc HD Cap Screw (2 Req.)	62	Lock Washer (3 Req.)
15	Roll Pin	63	Studs (3 Req.)
16	Spring	64	Socket Set Screw
17	Bearing	65	Adjustable Plate
18	Speed Change Shaft	66	HI-LOW Detent Plunger
19	Handle	67	Spring
20	Caution Plate	68	Socket Cap Screw (2 Req.)
21	Speed Change Handwheel	69	Bakelite Bull Handle
22	Flat Hd. Cap Screw (2 Req.)	70	HI-LOW Shift Crank
23	Plastic Face Plate	71	HI-LOW Pinion Block
24	Set Screw	72	Roll Pin (1 Req.)
25	Socket HD Cap Screw (4 Req.)	72a	Socket HD Cap Screw (2 Req.)
30	Worm Gear	73	Socket Cap Screw (4 Req.)
31	Bearing	77	Socket Set Screw
33	Speed Changer Spur Gear	78	Key (2 Req.)
35	Speed Change Chain Drum	79	Ball Bearing (2 Req.)
36	Belt	80	Bull Gear Pinion Counter Shaft
38	Timing Pulley Clutch Sleeve	81	Key
39	Splined Gear Hub	82	Wave Spring Washer
40	Spindle Bull Gear Assembly	83	Bull Gear Pinion
41	Ball Bearing (2 Req.)	84	Bull Gear Pinion Bearing Cap
42	Snap Ring (2 Req.)	85	Socket HD Cap Screw (2 Req.)
43	Bull Gear Bearing Spacer	86	Timing Belt Pulley
45	Vert. Tee Bolts (3 Req.)	87	Jam Nut
46	Steel Washer (3 Req.)		

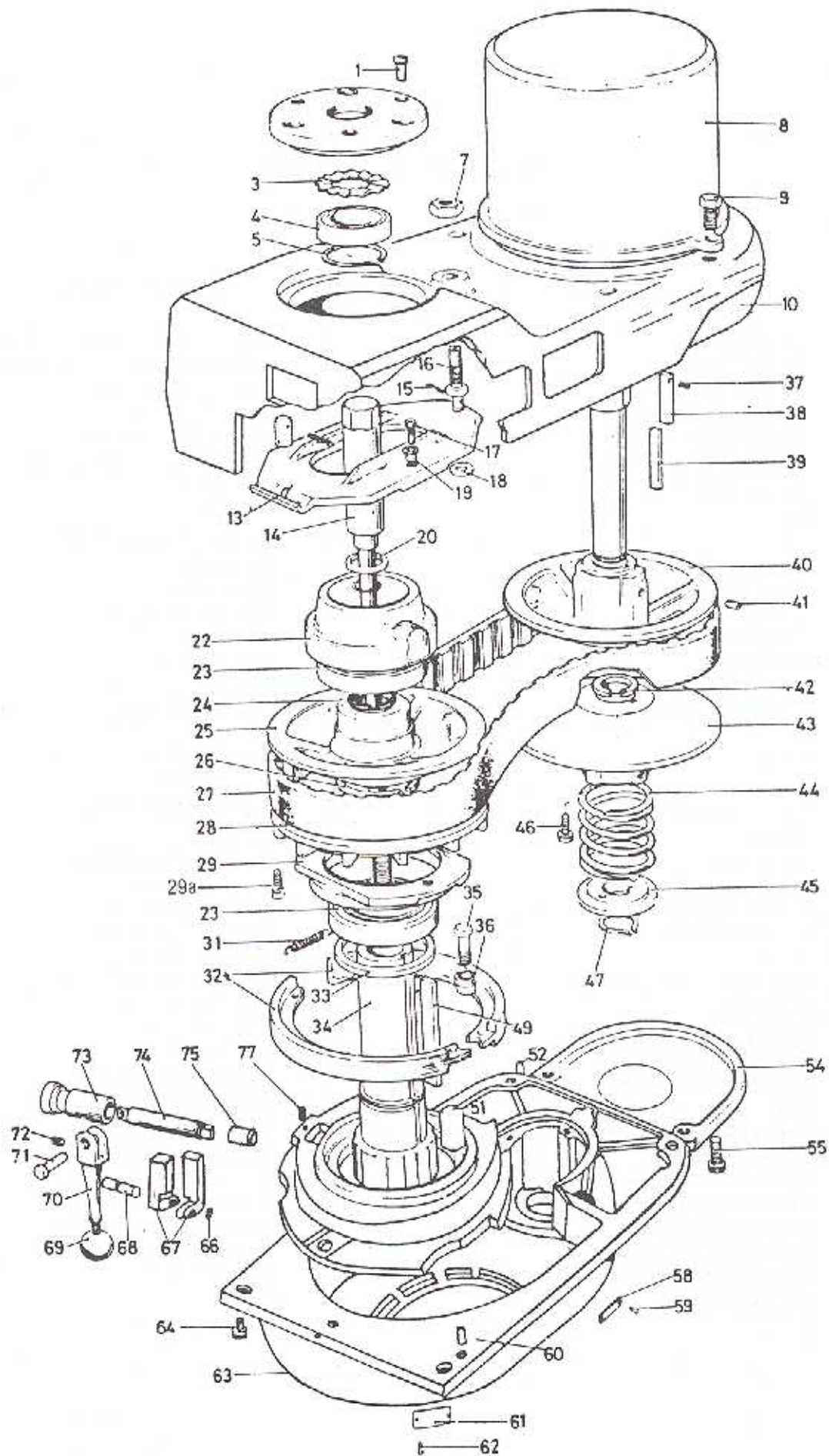

## 2J HEAD BACK GEAR

ITEM NO.	DESCRIPTION	ITEM NO.	DESCRIPTION
1	Socket Cap Screw (3 Req.)	40	Stationary Motor Varidisc
3	Spring Washer	41	Socket Set Screw
4	Ball Bearing	42	Plastic Insert (2 Req.)
5	Snap Ring No.	43	Adjustable Motor Varidisc Assembly
6	Socket HD Cap Screw (2 Req.)	44	Spring for Varidisc Motor Shaft
7	Hex Jam Nut	45	Adjustable Varidisc Spring Collar
8	Motor 2 HP (complete unit) 230/460 3/60	46	Socket HD Cap Screw (2 Req.)
9	Hex HD Screw (2 Req.)	47	Ret. Ring
10	Belt Housing	48	Socket Cap Screw
13	Speed Change Plate	49	Plastic Key
14	Drawbar	51	Key
15	Cotter Pin	52	Taper Pin
16	Speed Change Plate Pivot Stud	53	Belt Housing Base
17	Socket HD Cap Screw (2 Req.)	54	Motor Pulley Cover
18	Washer	55	Socket Cap Screw
19	Pivot Sleeve (2 Req.)	58	HI-LOW Range Nameplate
20	Draw Bar Washer	59	Drive Screw (4 Req.)
22	Spindle Pulley Bearing Sliding Housing	60	Taper Pin (2 Req.)
23	Ball Bearing	61	Quill Feed Nameplate
24	Plastic Insert (2 Req.)	62	Rivets (4 Req.)
25	Adjustable—Driven Varidisc	63	Gear Housing
26	Snap Ring No.	64	Round HD. Machine Screw (3 Req.)
27	Belt	65	Gear Housing Plate
28	Stationary Driven Varidisc	66	Snap Ring
29	Brake Bearing Cap	67	Brake Finger Pivot Stud
29a	Socket HD Cap Screw (2 Req.)	68	Brake Operating Finger
30	Ball Bearing	69	Bakelite Ball Handle
31	Brake Spring (2 Req.)	70	Brake Lock Handle
32	Brake Shoe Assembly (2 Req.)	71	Brake Lock Pin
33	Spindle Pulley Spacer	72	Socket Set Screw
34	Spindle Pulley Hub	73	Sleeve for Brake Lock Shaft
35	Hex HD. Screw	74	Brake Lock Shaft
36	Brake Shoe Pivot Sleeve	75	Brake Lock Cam
37	Roll Dowel Pin	76	Roll Pin
38	Drive Key	77	Socket Set Screw
39	Key for ADJ Varidisc Motor Shaft		

## CENTRAL LUBRICATING OIL-FEEDING EQUIPMENT

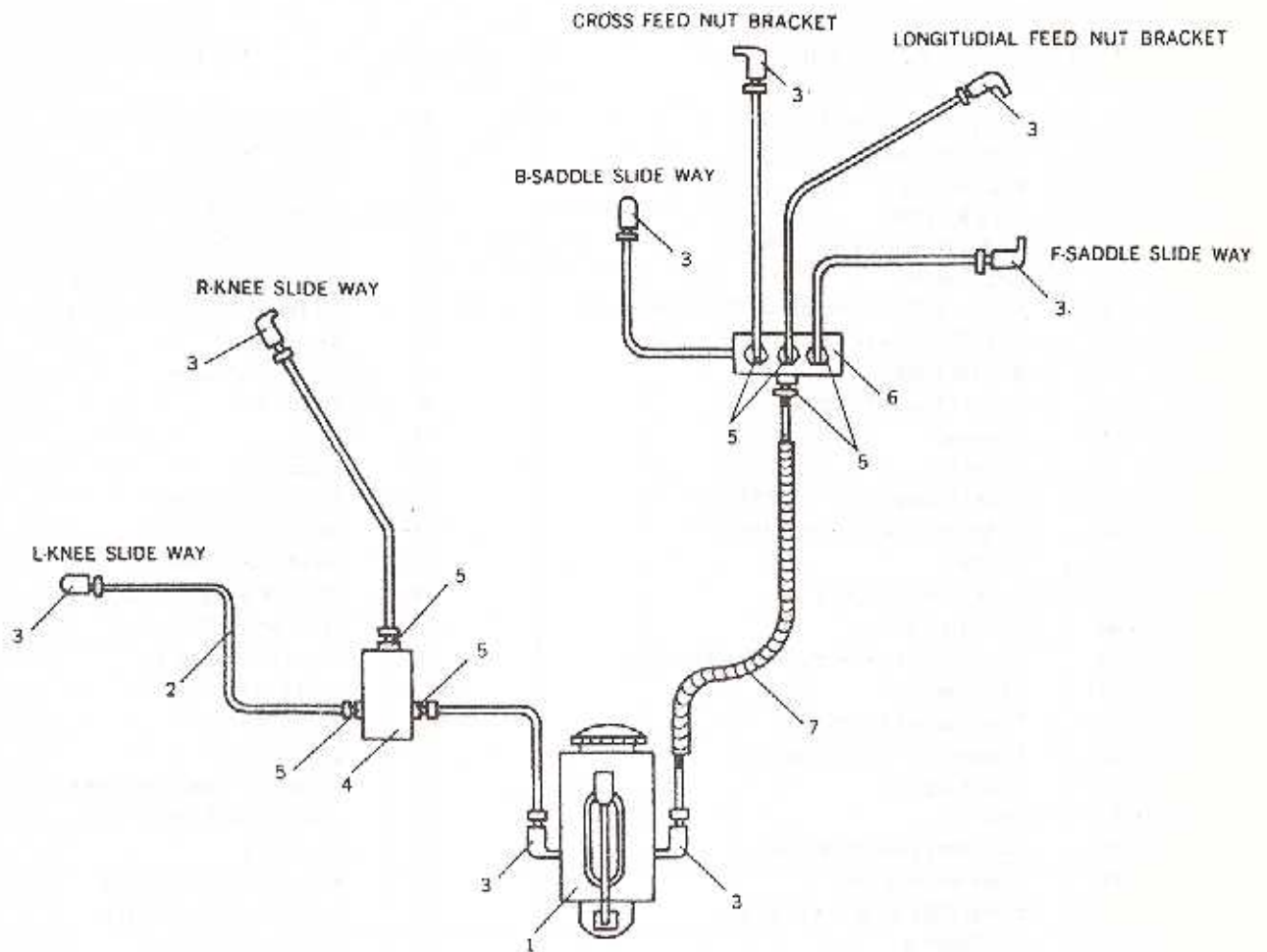

ITEM NO.	PARTS NO.	DESCRIPTION
1	9001	Hand Oiler
2	9002	Aluminum Pipe
3	9003	Elbow Joint (8 Req.)
4	9004	T-Joint
5	9005	Straight Joint (7 Req.)
6	9006	Oil Regulating Distributor
7	9007	Outside Steel Flexible Tube