

# OPERATION MANUAL

## TURRET MILLING MACHINE

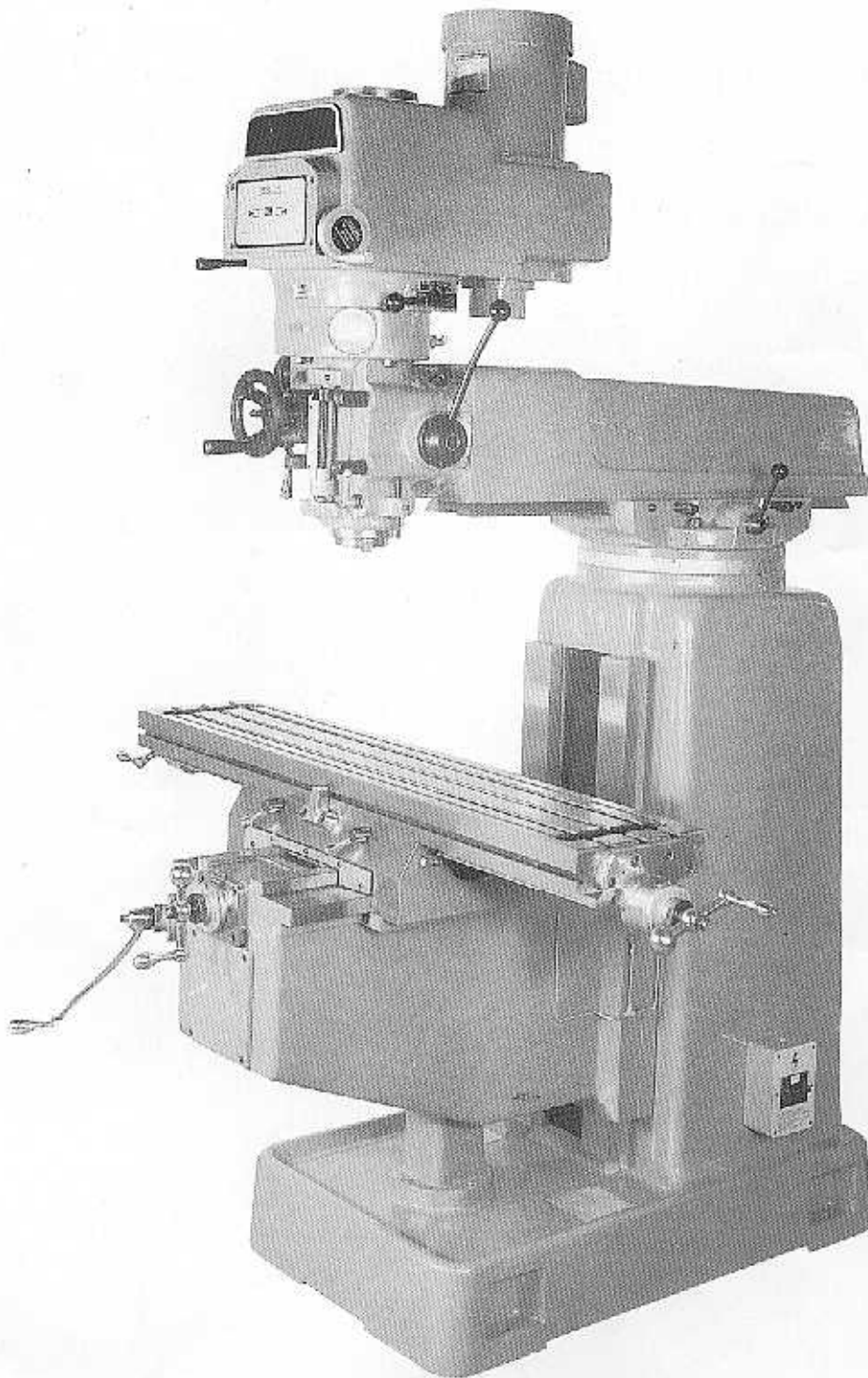

## TABLE OF CONTENTS

	<u>Page</u>
Machine Specifications	3
Milling Head Specifications	4
Uncrating	5
Cleaning	5
Lifting Machine	6
Placing on Solid Foundation	7
Leveling Machine	7
Handles	7
Connecting Power Supply	7
Alignment of Head	9
Lubrication	9
Adjustment of Table Gib	10
Adjustment of Saddle and Knee Gibs	10
Clamping Table, Saddle and Knee	11
Removing Table	12
Removing Saddle	12
Mounting Vari Drive Attachment to Ram Adapter	14
Lubrication	14
Operating Instructions	14
Spindle Brake	16
High-Low Range Switch	16
Hi-Neutral-Lo Lever	16
Power Feed Transmission Engagement Crank	17
Quill Feed Selector	17
Feed Reversing Knob	17
Manual Feed	17
Feed Control Lever	18
Quill Feed Handle	18
Quill Stop	18
Micrometer Adjusting Nut	18
Position of Ram	19
Operating Instructions	19
Removing Motor	20
Changing Vari-Drive Belt	22
Changing Timing Belt	23
Basic Machine	24
Leadscrew Assembly	26
5K Head Top Housing	28
5K/5VK Head	30
5VK Head Top Housing	34
5VK Head Back Gear	38
Central Lubrication Oil-Feeding Equipment.	38

\*Specifications subject to change without prior notice

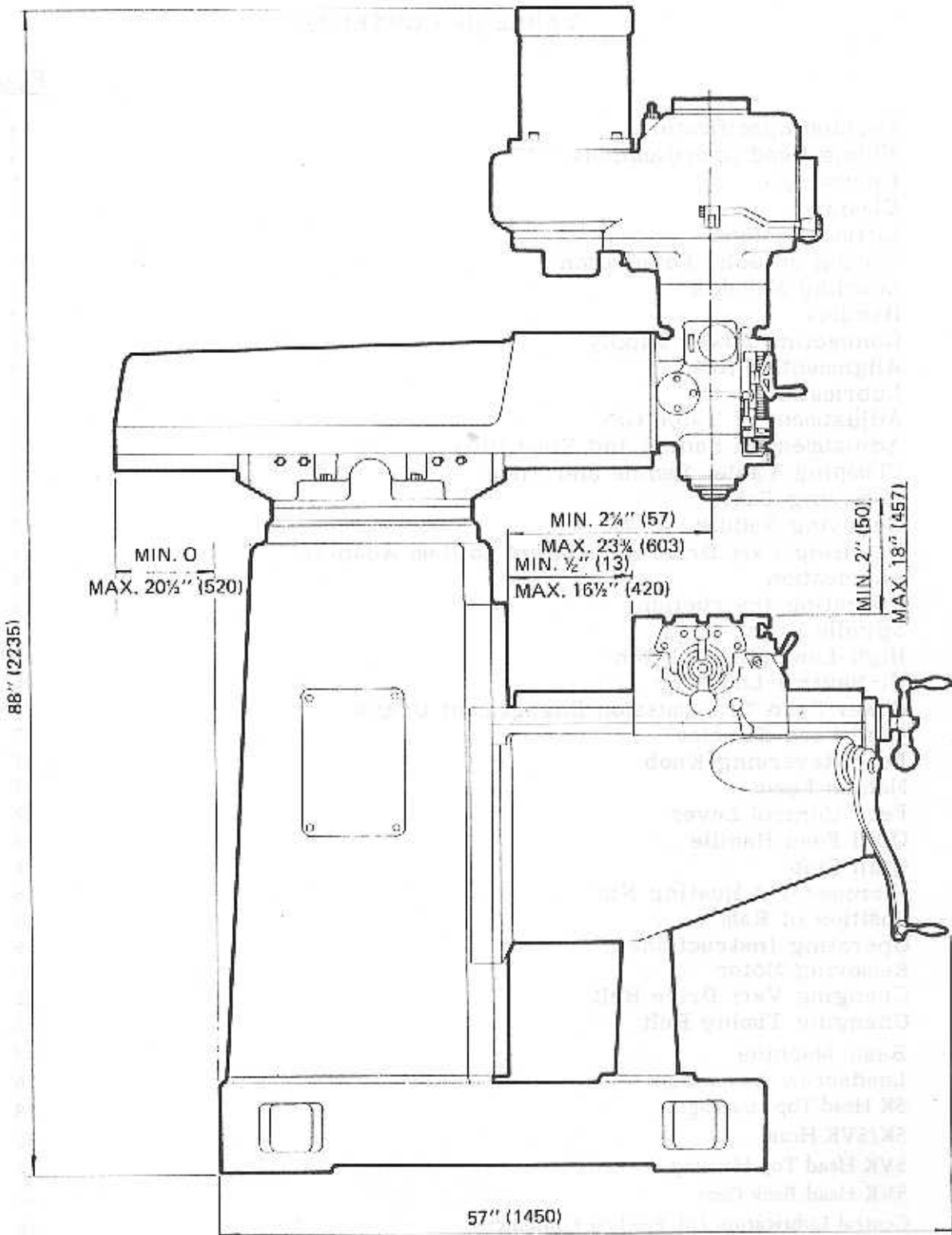

Figure 1. Basic Dimensions

## BASIC MACHINE SPECIFICATIONS

### Range

Table travel (X-axis)	36 in. (914mm)
Saddle travel (Y-axis)	16 in. (406mm)
Quill travel	5½ in. (140mm)
Knee travel (Z-axis manual)	16 in. (406mm)
Ram travel	2¼ in. (546mm)
Throat distance (min.)	2½ in. (57mm)
(max.)	23-3/8 in. (603mm)
Table to spindle nose gage line (min.)	2 in. (50mm)
Max. weight of workpiece	850 lbs. (386 kg.)

### Table

Overall sizes	10 in x 50 in (254mm x 1270mm)
T-Slots	3 on 2-1/2 in. (63.5mm) centers
T-Slot size	5/8 in. (16mm)
Height above floor (max.)	50 in. (1270mm)

### Milling

Feed rate (Power optional)

### Space and weight

Floor area	7 x 10ft. (2.1 x 3.1m)
Height	88 in. (2235mm)
Net weight	3500 (1600 kg)
Shipping weight	3850 lbs. (1750 kg)

### Power

Electrical supply - 60 Hz., 3 phase 220/230/380/415/440/460/575V

### Color

Standard - Machine Gray

MILLING HEAD SPECIFICATIONS

MODEL	HEAD (5K)	HEAD 5VK
Power	5 HP	5 HP
Motor RPM	1720 RPM	1720 RPM
Speed Ranges - RPM Low HIGH	10 Steps 75, 125, 200, 300, 450 600, 1000, 1550, 2350, 3600	Variable Speed 75 - 550 550 - 3800
Quill Travel	5½" (140mm)	5½" (140mm)
Quill Diameter	4.173" (106mm)	4.173" (106mm)
Spindle Taper	I.S.O. 40	I.S.O. 40
Spindle Diameter	3½" (89mm)	3½" (89mm)
Spindle Feed Rate	0.0017"/Rev (0.044mm)	0.0017"/Rev (0.044mm)
Spindle Feed Rate	0.0032"/Rev (0.083mm)	0.0032"/Rev (0.083mm)
Spindle Feed Rate	0.0054"/Rev (0.138mm)	0.0054"/Rev (0.138mm)
Drilling Capacity-Manual	1¼" (32mm) dia.	1½" (32mm) dia.
Drilling Capacity-Power	5/8" (16mm) dia.	5/8" (16mm) dia.
Boring Capacity	8.0" (200mm) dia.	8.0" (200mm) dia.
Milling Capacity	2.5 in <sup>3</sup> /min	2.5 in <sup>3</sup> /min
Spindle to Column-Minimum	2¼" (37mm)	2½" (57mm)
Spindle to Column-Maximum	23½" (603mm)	23¾" (603mm)

### UNCRATING:

Carefully remove protective crating so machine and parts are not marred or damaged. In the event of damage in transit, **IMMEDIATELY** notify the distributor from whom the machine was purchased, as well as the transportation company making delivery.

### CLEANING:

Thoroughly clean protective coating from machine with suitable cleaning solution.

### WARNING

**IT IS NOT RECOMMENDED THAT GASOLINE OR ANY OTHER HIGHLY INFLAMMABLE CLEANING AGENT BE USED.**

Do not move the table, knee, saddle or ram until all ways have been well cleaned and lubricated. Then, by hand, move table, saddle, and knee to limit stop in one direction. Clean and lubricate exposed ways and then move each unit to the opposite limit stop and similarly clean and lubricate the exposed ways. Loosen bolts to unlock ram and move forward and backward the full length to clean and lubricate.

### POSITIONING HEAD UPRIGHT:

Loosen four locknuts (#143, page 35), out to detent and rotate head to vertical position. Proceed with alignment of head as described on page 9. Tighten nuts evenly, using normal pressure. Care should be taken to avoid excessive tightening since this will cause distortion in the quill. Tighten all nuts to 30 ft. lbs. torque, then repeat to 75 ft. lbs.

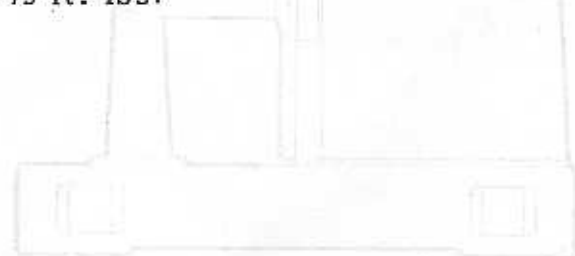

## LIFTING THE MACHINE

Note position of ram and table when lifting with sling.

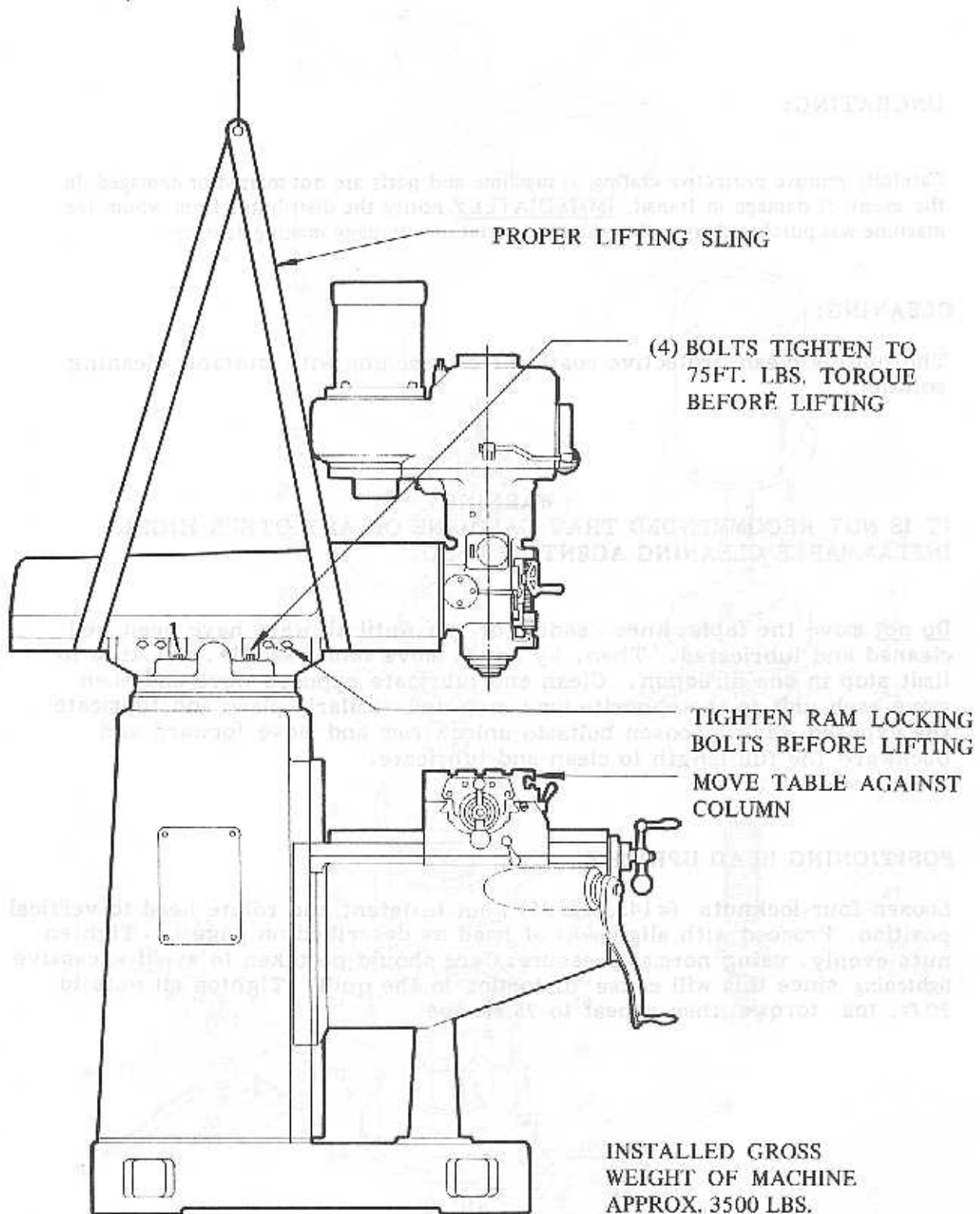

FIGURE 2 LIFTING THE MACHINE

### LIFTING AND PLACING ON SOLID FOUNDATION:

Machine should be lifted by placing a sling under the ram as illustrated on page 6.

The column and base are a one piece casting. When setting machine on a concrete foundation, it is advisable to use a little grout (thin mortar) to take care of any unevenness in the concrete as well as to provide a solid foundation at all points.

When setting machine on a floor that is uneven, shims should be used to correct this condition. See Figure 3 for installation layout.

#### NOTE

IT IS RECOMMENDED THAT THE MACHINE BE SECURED TO THE FLOOR TO PREVENT MOVEMENT OR TIPPING DUE TO OFF-CENTER LOADING.

Before securing machine to floor (i.e. tightening hold down bolts), make certain all four corners are making contact with floor or shims, after machine is leveled. If this is not done, it is possible to twist the column and put a bind in the ways.

### LEVELING MACHINE:

Set machine by leveling the work table lengthwise and crosswise with a precision level.

### HANDLES:

When crating, the three ball crank handles are sometimes turned to face the machine. In these cases the handles should be reversed before operating.

### CONNECTING POWER SUPPLY:

To connect the power have a qualified electrician proceed as follows:

1. Check motor wiring to ensure it is compatible with power supply.
2. Connect machine wiring to power supply making sure connection complies to all local electrical code.
3. Check for correct spindle rotation. In the HIGH SPEED range, the spindle should rotate clockwise when viewed from the top of the machine.

#### NOTE

DRUM SWITCH AND HI-NEUTRAL-LO LEVER MUST BE IN HI RANGE.



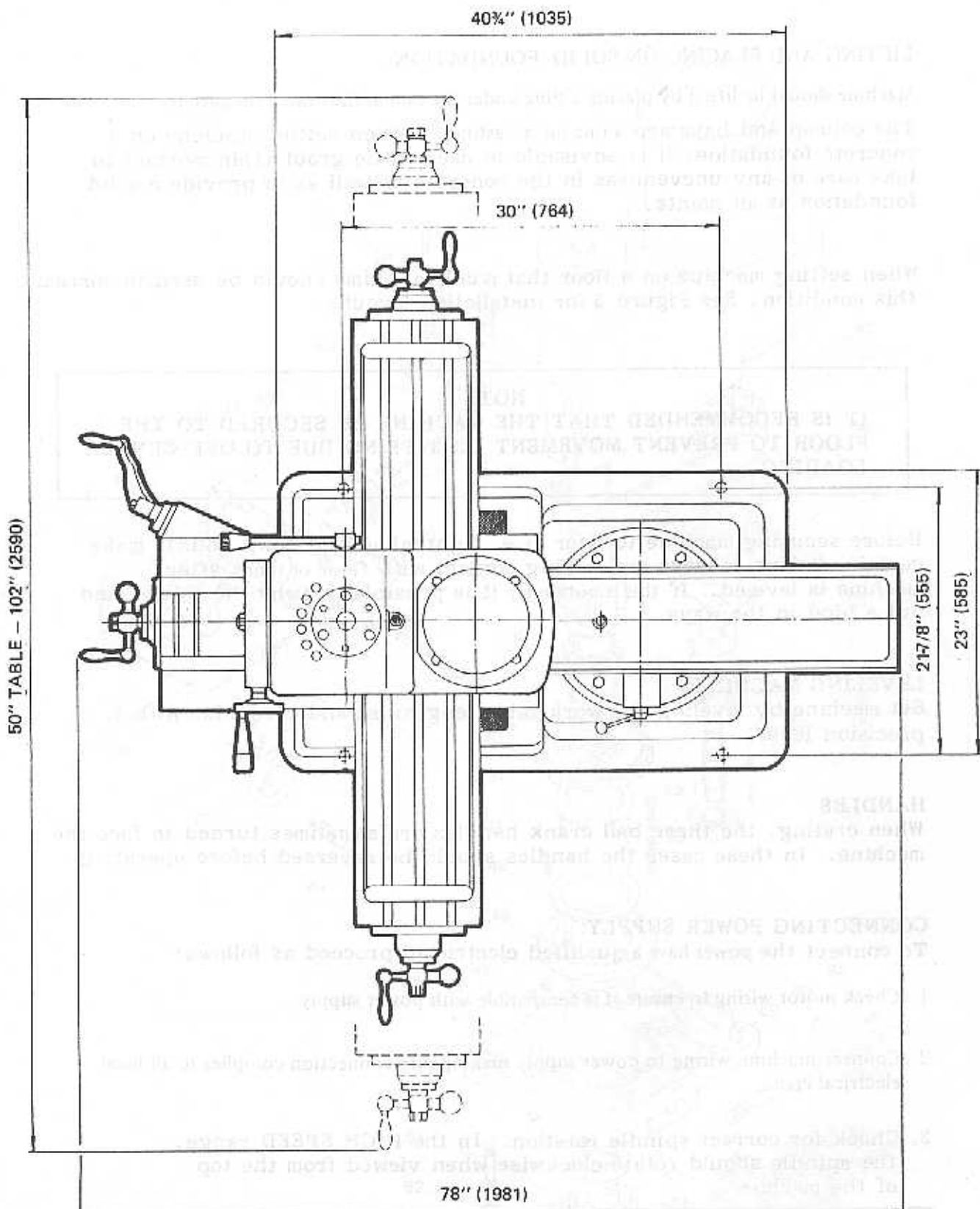

NOTE  
 DRUM SWITCH AND BI-NEUTRAL LEVER MUST BE IN HI RANGE

FIGURE 3 INSTALLATION LAYOUT

## ALIGNMENT OF HEAD:

In case of precision work where it is necessary to have head perfectly square with the table, use method described below. To set head square with table, see Figures 4. Loosen four locknuts (#143, page 34). but leave longitudinal axis, mount indicator as shown in Figure 4.

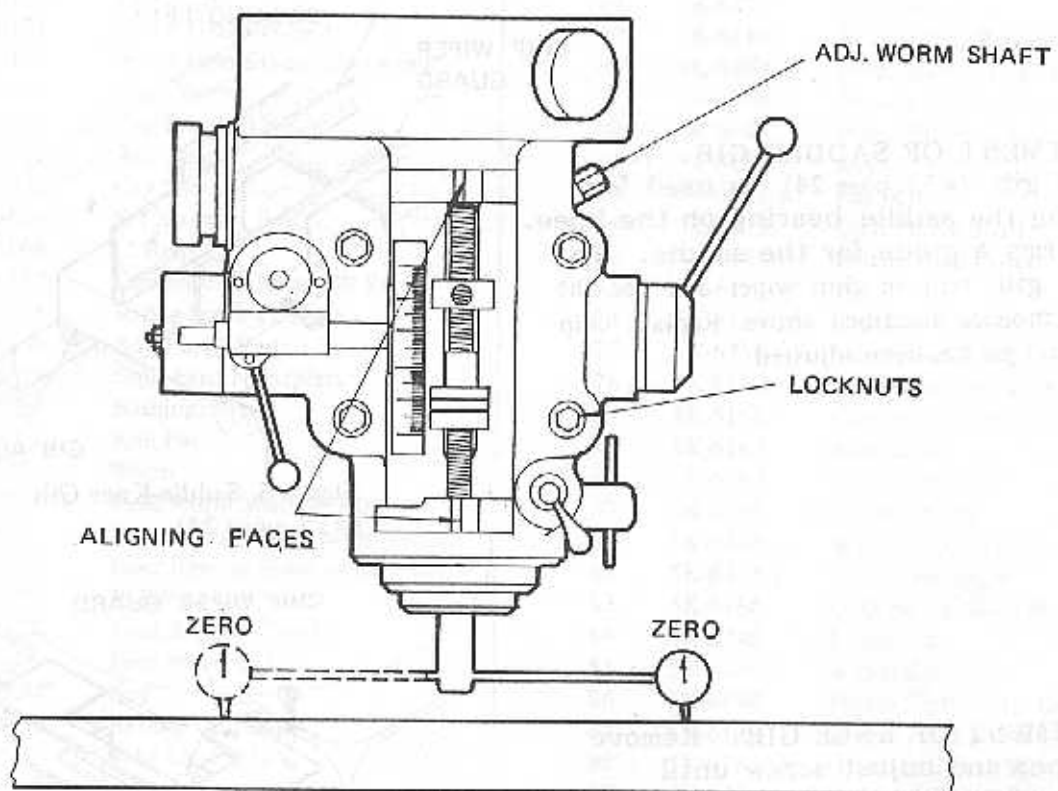

Figure 4. Head Alignment X Axis

## LUBRICATION:

Do not operate until properly lubricated:

- (A) Way surfaces and lead screws  
Sunoco waylube #80 or equivalent.
- (B) Milling Heads (Spindle Bearings)  
S.A.E. 10 or 10W light oil.
- (C) Motors are greased for life of bearings.

**ADJUSTMENT OF TABLE GIB.** The table is provided with a full length tapered gib (#63, page 24) in the saddle, and an adjusting screw on the left side. To take up gib, tighten gib adjusting screw (#43, page 24) slightly and repeat until a slight drag is felt when moving the table by hand.

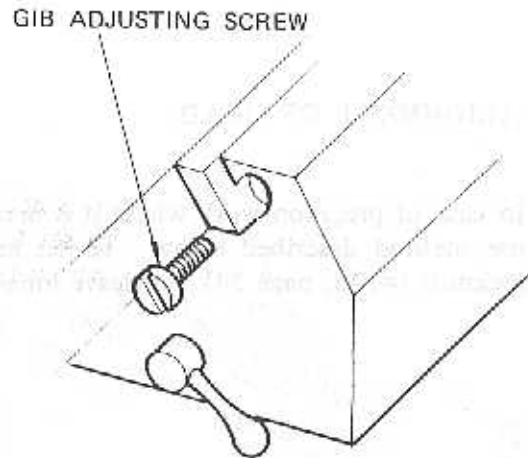

Figure 5. Saddle/Table Gib (#63, page 24)

**ADJUSTMENT OF SADDLE GIB.** A tapered gib (#53, page 24) is used for adjusting the saddle bearing on the knee. This forms a guide for the saddle. To tighten gib, remove chip wiper and use the same method as described above. Replace chip wiper after gib has been adjusted.

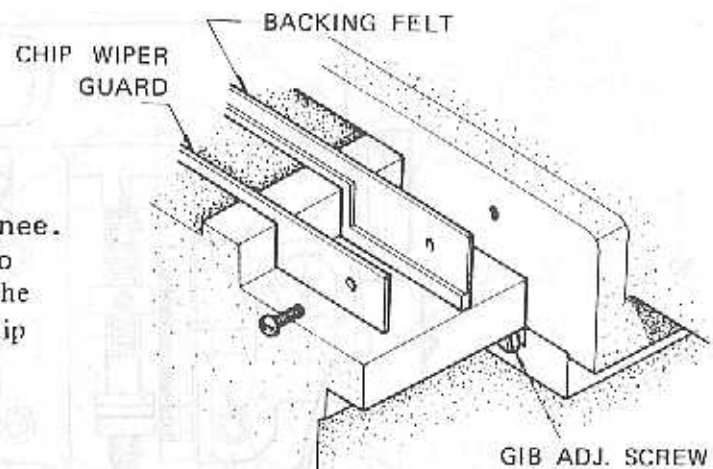

Figure 6. Saddle-Knee Gib (#53, page 24)

**ADJUSTMENT OF KNEE GIB.** Remove chip wiper and adjust screw until smooth movement is attained. Replace chip wiper.

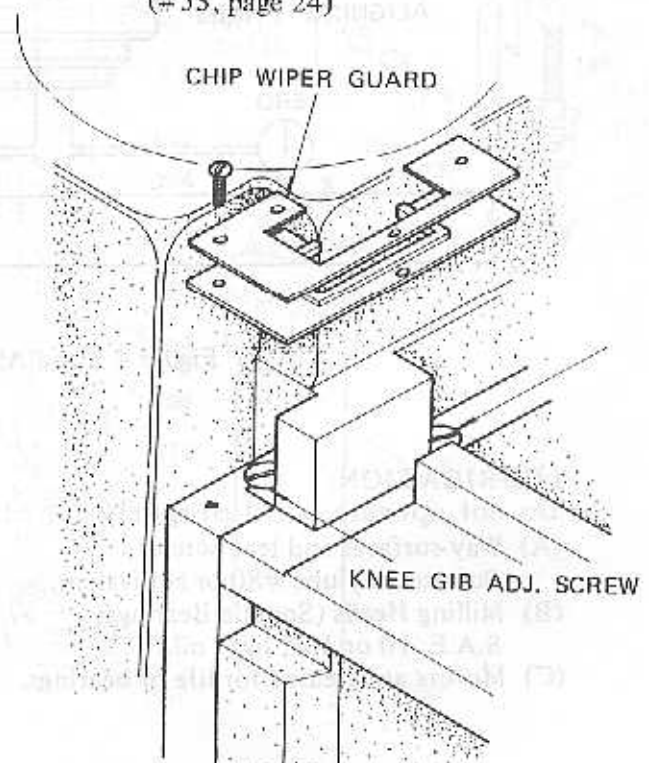

Figure 7. Knee-Column Gib (#41, page 24)

**REMOVING TABLE:**

Remove the following: ball crank, handles, dial holders and bearing brackets. Turn the lead screw all the way out and slide the table from the saddle. See Fig. 8.

**REMOVING SADDLE:**

Follow the same procedures as removing table; however, it is necessary to remove the entire front bracket assembly. Next, remove the cross feed nut bracket which can only be done by removing the table. See Fig. 8.

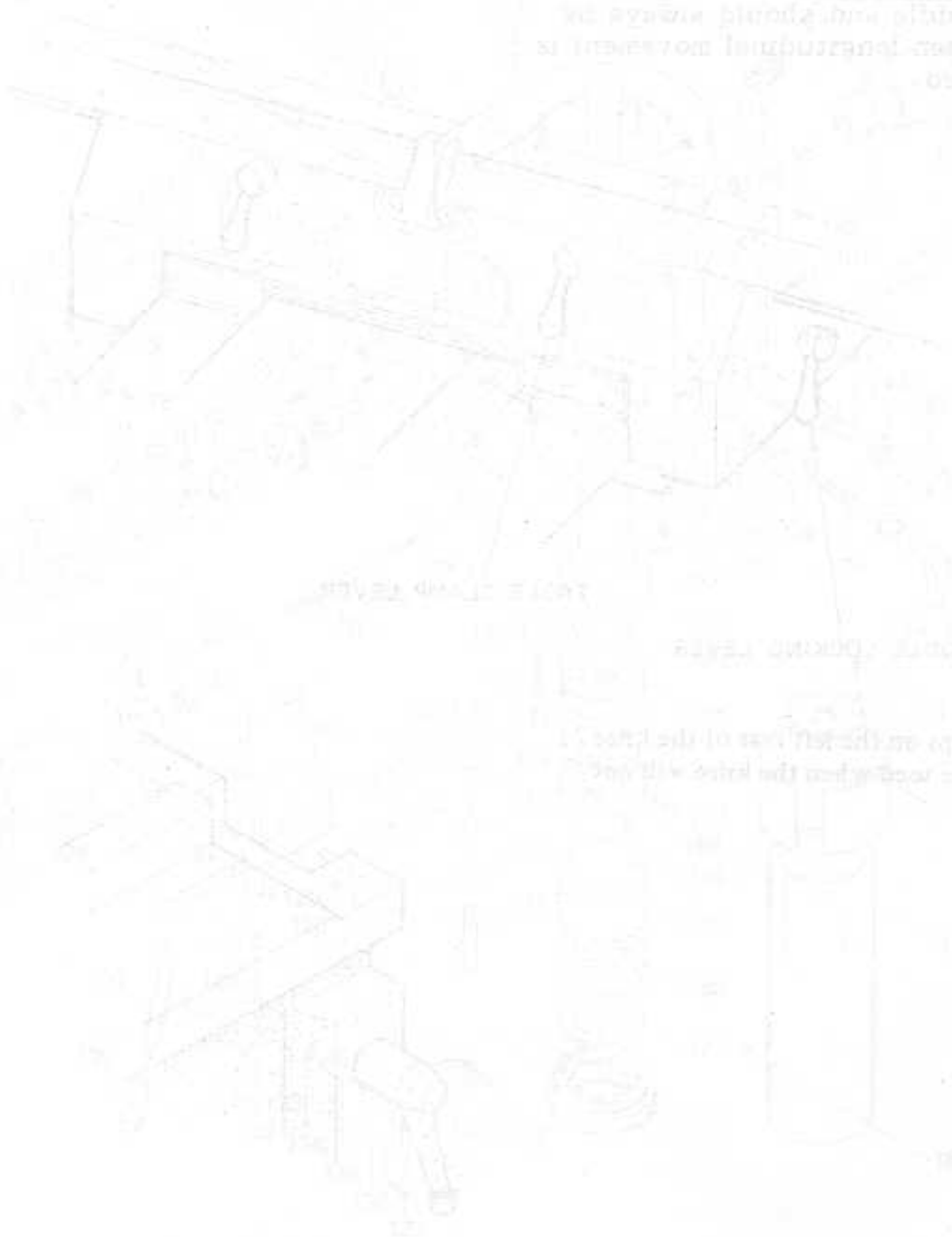

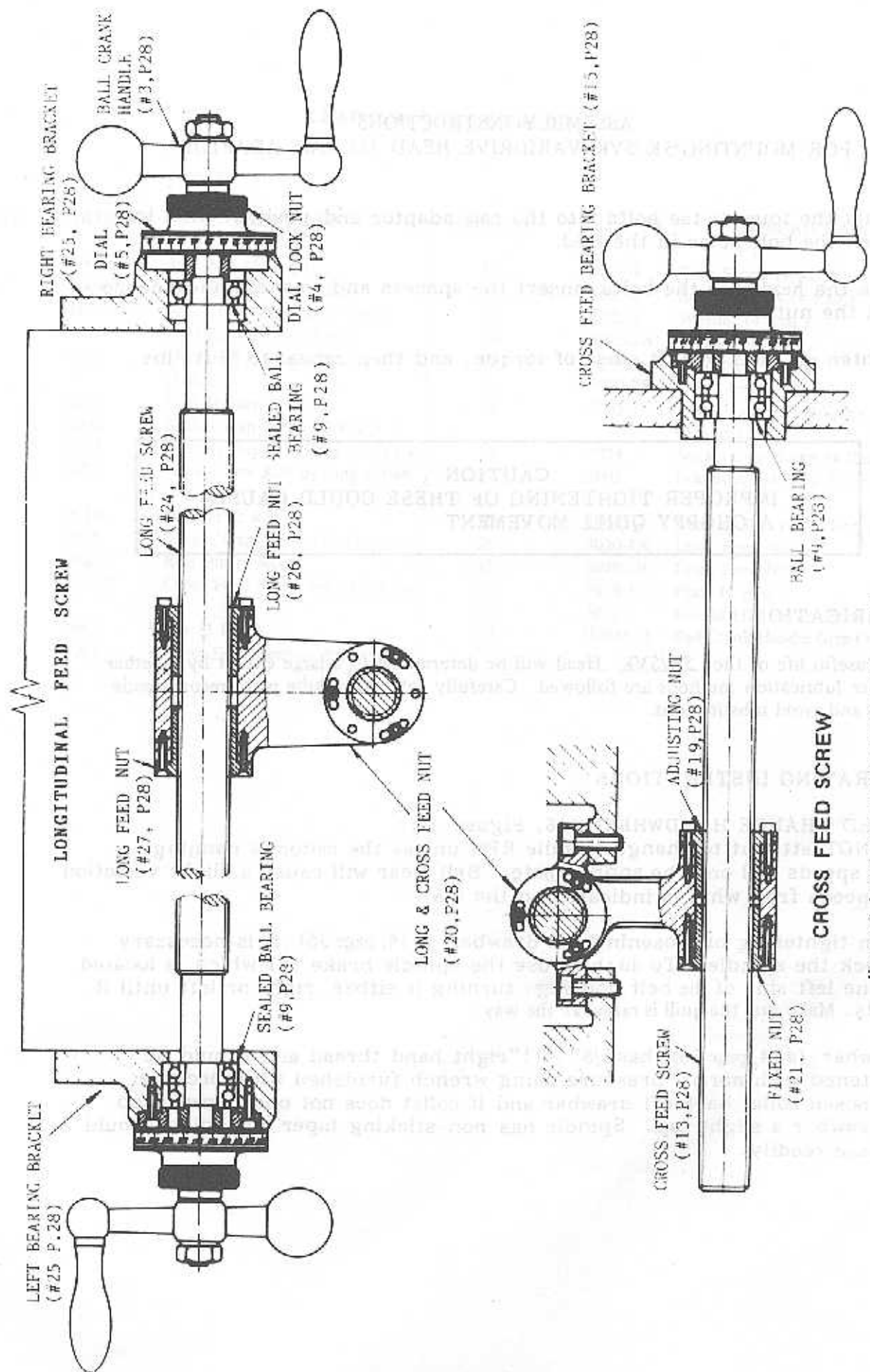

Figure 8. Longitudinal and Cross Feed Assembly

**ASSEMBLY INSTRUCTIONS  
FOR MOUNTING 5K/5VK VARIDRIVE HEAD TO RAM ADAPTOR**

Insert the four (4) tee bolts into the ram adaptor and position them to match the bolt holes in the head.

Slide the head onto the bolts, insert the spacers and washers and secure with the nuts.

Tighten all nuts to 30 ft. lbs. of torque, and then repeat to 75 ft. lbs.

<p><b>CAUTION</b> <b>IMPROPER TIGHTENING OF THESE COULD CAUSE</b> <b>A CHOPPY QUILL MOVEMENT</b></p>
--

**LUBRICATION:**

The useful life of the 5K/5VK Head will be determined to a large extent by whether proper lubrication methods are followed. Carefully follow the lube plate recommendations and avoid substitutions.

**OPERATING INSTRUCTIONS:**

**SPEED CHANGE HANDWHEEL (16, Figure 9):**

DO NOT attempt to change spindle RPM unless the motor is running. Dial speeds will only be approximate. Belt wear will cause a slight variation in speeds from what is indicated on the dial.

When tightening or loosening the drawbar (#14, page 36), it is necessary to lock the spindle. To do this, use the spindle brake (3) which is located on the left side of the belt housing, turning it either right or left until it binds. Make sure the quill is raised all the way.

Drawbar (#14, page 36) has 5/8" - 11" right hand thread and should be tightened with normal pressure using wrench furnished with machine. To loosen collet, back off drawbar and if collet does not open, given top of drawbar a slight tap. Spindle has non-sticking taper and collet should release readily.

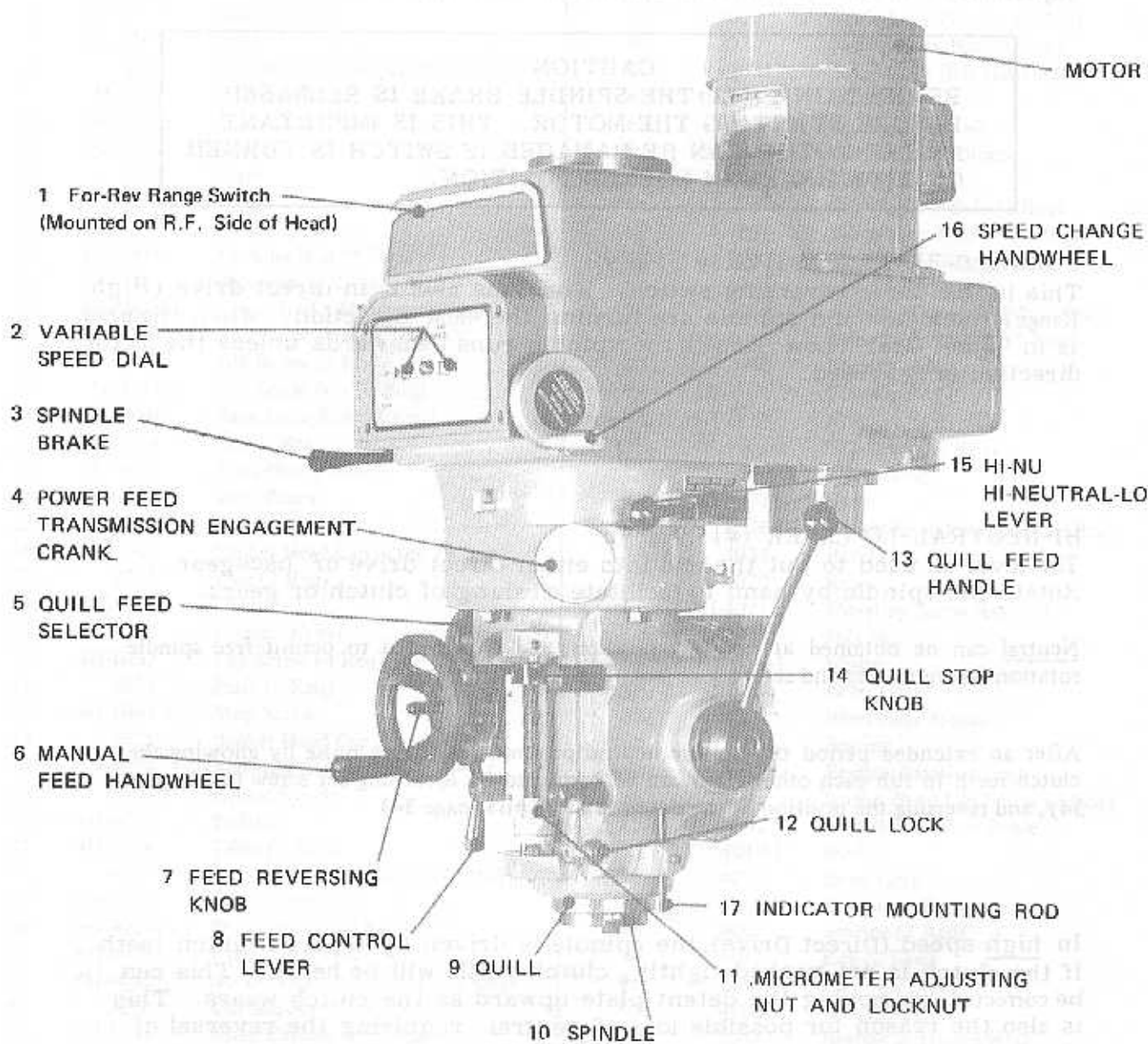

Figure 9. 5VK Milling Head

**SPINDLE BRAKE (3, Figure 9):**

Brake lever can be moved in either direction to stop spindle. When locking spindle, lever should be moved right or left and then raised. There are no adjustments on brake so it must be replaced when worn out.

**CAUTION**

**BE CERTAIN THAT THE SPINDLE BRAKE IS RELEASED BEFORE STARTING THE MOTOR. THIS IS IMPORTANT AS THE MOTOR CAN BE DAMAGED IF SWITCH IS TURNED ON WITH BRAKE IN LOCKED POSITION.**

**FORWARD-REVERSE SWITCH (#1, Fig. 9):**

This is the motor reversing switch. When the head is in direct drive (High Range), the motor and spindle are turning the same direction. When the head is in "Back Gear" (Low Range), the spindle runs backwards unless the motor direction is reversed.

**HI-NEUTRAL-LO LEVER (#15, Fig. 9):**

The lever is used to put the head into either direct drive or backgear. Rotate the spindle by hand to facilitate meshing of clutch or gears.

Neutral can be obtained at mid-way position, and is provided to permit free spindle rotation for indicating and set-up.

After an extended period of use, the neutral position may cause noise by allowing the clutch teeth to rub each other. This can be corrected by loosening set screw (#64, page 34), and reversing the position of the detent plate (#65, page 34)

In high speed (Direct Drive), the spindle is driven by tapered clutch teeth. If the clutch is not meshed tightly, clutch rattle will be heard. This can be corrected by moving the detent plate upward as the clutch wears. This is also the reason for possible loss of neutral, requiring the reversal of the detent plate.

**CAUTION**

**DO NOT shift Hi-Lo Lever while motor is running.**



**POWER FEED ENGAGEMENT CRANK (#4, Fig.9):**

Engages power feed worm gear. When lever is in right hand hole, power feed is engaged. To disengage, pull knob out and turn crank in clockwise or down direction and move to opposite position.

**NOTE**

HANDLE MUST BE MOVED IN CLOCKWISE DIRECTION TO ENGAGE OR DISENGAGE POWER FEED. IF HANDLE IS MOVED COUNTER-CLOCKWISE, NO DAMAGE WILL BE DONE, BUT NOTHING WILL HAPPEN.

**CAUTION**

POWER FEED GEAR MAY BE ENGAGED WHILE SPINDLE IS TURNING, HOWEVER, IT SHOULD BE ENGAGED SLOWLY TO AVOID DAMAGE TO THE WORM GEAR. THE GEAR MAY BE DISENGAGED AT ANY TIME. DO NOT USE POWER FEED AT SPEED ABOVE 3000 RPM.

**IMPORTANT :** It is recommended that the Power Feed worm gear be disengaged whenever the power feed is not required. This will avoid unnecessary wear on power feed worm gear.

**QUILL FEED SELECTOR (#5, Fig. 9):**

This crank is used to select the feed rate to be used. It is shifted by pulling knob out and turning from one position to another. Feed rates are stamped on cover below each hole. Feed is more readily engaged with spindle running.

**FEED REVERSE KNOB (#7, Fig. 9):**

Position of this knob depends upon direction of spindle rotation. If boring with right hand cutting tools, pull feed handle towards operator until clutch becomes engaged.

Neutral position is between forward and reverse position. It is recommended that the handle be left in neutral position when not in use.

**MANUAL FEED HANDWHEEL (#6, Fig. 9):**

Feed reversing knob should be in neutral position and feed control lever (#8, Fig. 9) engaged. Clockwise rotation of handwheel moves quill down. Manual Feed Handwheel and quill feed handwheel may be disengaged by moving them outward approximately 1/8".

NOTE

The feed control lever must be engaged in order to use manual feed controls. The Quill Feed Handle and Manual Feed Handwheel may be taken off when not in use.

FEED CONTROL LEVER (#8, Fig. 9):

Engages over-load clutch on pinion shaft when moved left and will stay engaged until either quill stop comes in contact with micrometer adjusting nut forcing feed control lever to disengage automatically, or released manually by moving lever to right.

NOTE

The Feed Control Lever is carefully set at plant to disengage automatically when quill stop goes against micrometer adjusting nut or against throw out pin at top. However, if this should go out of adjustment, it may easily be brought back by regulating the socket set screw located at bottom of tripping rod (item no. 161, page 30)

CAUTION

WHEN ADJUSTING THE SOCKET SET SCREW, CHECK AUTOMATIC DISENGAGEMENT IN BOTH DIRECTIONS: THAT IS WITH QUILL-STOP NUT (#150, page 30) AGAINST THE FEED TRIP LEVER (#160, page 30) FOR DOWN POSITION. AND AGAINST REVERSE TRIP BALL LEVER (#67, page 30) FOR THE UP POSITION.

QUILL FEED HANDLE (#13, Fig. 9):

May be removed by simply pulling handle off. It is recommended that handle be disengaged when using power feed.

QUILL STOP KNOB (#14, Fig. 9):

Is used to disengage power feed in either direction as well as acting as a depth stop when working to a given depth.

MICROMETER NUT (#11, Fig. 9):

This nut is used for setting of depths. Each graduation on nut indicates .001" of depth, it reads directly to scale mounted along side of it. Depths may be obtained by setting micrometer nut in conjunction with quill stop.

QUILL LOCK (#10, Fig. 9):

This is a friction lock to be used when quill is in stationary position such as for milling. It is recommended this lock be used whenever quill movement is not desired.

#### RAM POSITION

Ram can be moved by loosening two ram lock studs (#21, page 24) on turret (#11, page 24) and moving to desired position.

**CAUTION**  
CARE SHOULD BE TAKEN TO LOCK RAM  
SECURELY AFTER SETTING.

#### NOTE

It is recommended that on heavy milling work, head should be kept as close to column as possible, where maximum rigidity is obtained.

#### RECOMMENDATIONS :

Use 2, 3, or 4 flute end mills. Eight flute end mills are usually not as satisfactory for general milling. When using shell mills, face mills or any other tooling, proper machining practice should be observed.

Power feed can be used for drills up to 5/8" diameter in mild tool steel. Overload clutch is preset to hold up to 300 lbs. down pressure on quill. Use manual feed for drills over 5/8"

**CAUTION**  
THIS CLUTCH SHOULD NOT BE TAMPERED  
WITH IN THE FIELD.

#### OPERATING INSTRUCTIONS

**CAUTION**  
DO NOT TRY TO CHANGE SPINDLE SPEED ON 2VS VARI-  
DRIVE HEAD UNTIL MOTOR IS RUNNING. THIS COULD  
CAUSE PARTS BREAKAGE.

Spindle Feeds are adjusted by turning speed change handwheel (#21, page 34) on the front of the belt housing. There are two ranges shown, 75 to 550 and 550 to 3800

75-550 RPM obtained through the back-gear drive and is referred to as low range. To engage the back-gears, use the lever marked Hi-Neutral-Lo on the right side of the head. Move this lever to the "LO" position and use low range on the variable speed dial.

When shifting to "LO," DO NOT FORCE THE LEVER if the back gears do not mesh. Hold the lever so that the gears are clear of one another, rotate the spindle nose by hand until the gears line up, then put the unit in "LO" (back gear).

550-3800 RPM is direct drive and is the high range. The same procedure as previously described is used to select this range except the Hi-Neutral-Lo lever is set in the Hi position.

Wear on the vari drive belt, will cause a slight change in the speeds to that shown in windows (#23, page 34) on the dial. This can be corrected as follows. Crank the speed change handwheel (#16, Figure 9) snugly against the high speed stop. (This will be near the 3800 reading on the dial.) Use a tachometer to determine the spindle speed, then turn the pivot stud (#16, page 36), after loosening the jam nut (Item #7, page 38) until the spindle speed registers 3800 on the tachometer; tighten jam nut.

Now reposition the speed dial plate to match the tachometer reading. This is done by loosening the Hex nut (#1, page 34) until the spindle speed registers 3800 on the tachometer; tighten jam nut.

**CAUTION**  
DO NOT SHIFT THE HI-NEUTRAL-LO LEVER WHEN  
THE FEED GEAR IS ENGAGED.

DO NOT LOOSEN the 3 hex nuts (#61, page 34) on the upper part of the Quill Housing (#170, page 30). These are set at the factory and are used only for alignment.

#### REMOVING THE MOTOR (See Fig. 10):

Run the head to the lowest speed of either range and shut off the motor. This puts the Vari-Drive belt in the best position for disassembly.

1. DISCONNECT THE POWER and then remove the switch from the side of the belt housing.

2. Remove the cover (#54, page 36) (B - Figure 10) at the lower end of the motor shaft. Use two cover screws (#55, page 36) (A) to fasten the spring (#44, page 36) (C) on the lower end of the motor shaft, to the lower motor vari-drive pulley (#43, page 36). This will reduce the hazard of personal injury that is always present when a heavy spring is under compression. When the pulley, spring retainer (#45, page 36) and spring are securely fastened as a single unit, crank the speed change handwheel (#16, Figure 9) to top speed position.
3. Now remove the screws (#9, page 36) (D) that fasten the motor to the belt housing. The motor should be lifted slightly and pulled firmly away from the spindle and toward the rear of the belt housing. This will pull the vari-drive belt (#27, page 36) deeply into the spindle pulley (#25, page 36) providing the slack needed to slip the belt over the motor pulley (#43, page 36).
4. Now lift the motor high enough to rest the motor base GENTLY on the adjusting screw (#16, page 36) (E) seen directly in front of the motor flange. The belt can now be slipped over the lower pulley and the motor removed from the housing.

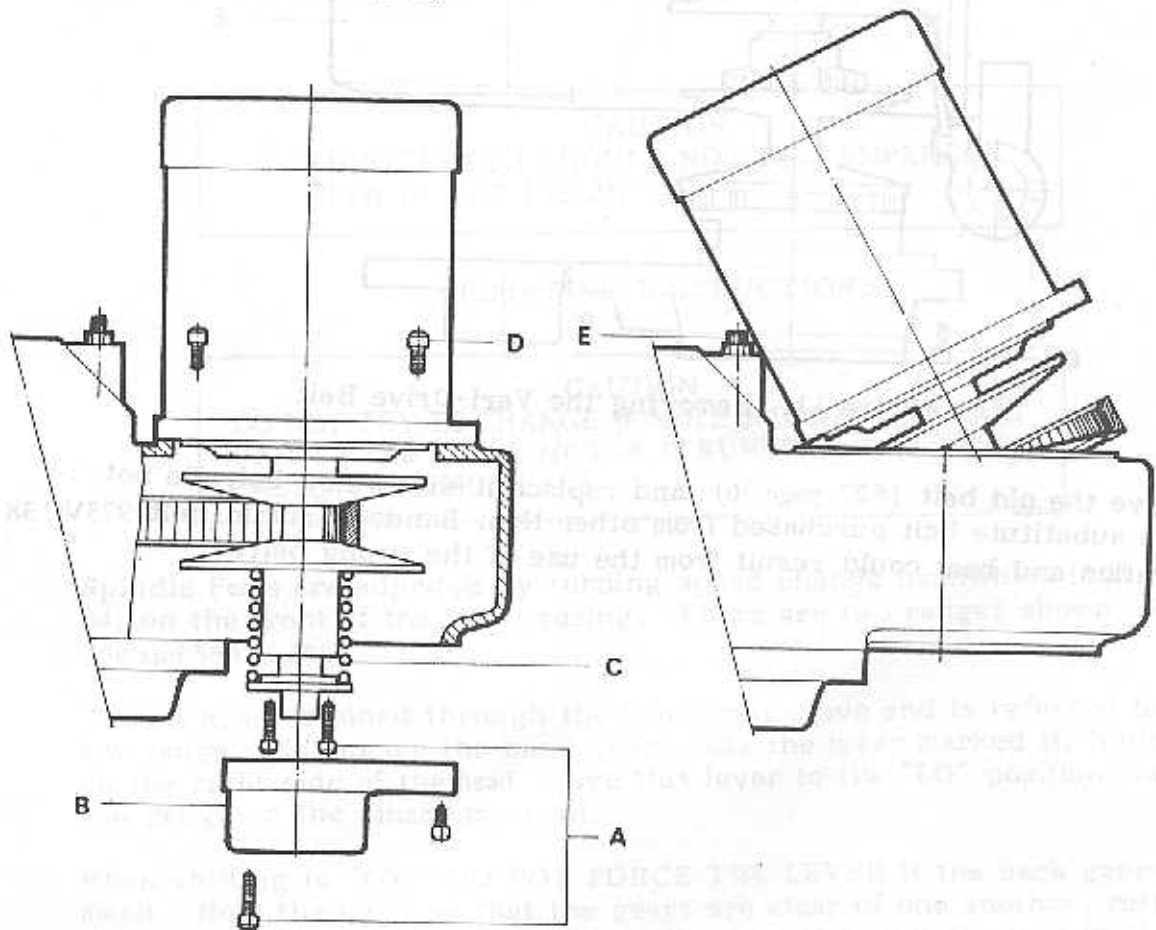

Figure 10. Removing the Motor (Side View)

### CHANGING VARI-DRIVE BELT (Figure 11)

Complete the previous procedures for removing the motor, then remove the three screws (#1, page 36) (A. Fig. 11) and lift out the top bearing cap (#13, page 34) (B). Looking down inside of the housing, locate and remove two socket head cap screws (#17, page 36) and sleeves (#19, page 36) (C). Next, remove the six screws (#56, page 36). (D), then holding the belt housing (E) to the base (#63, page 36).

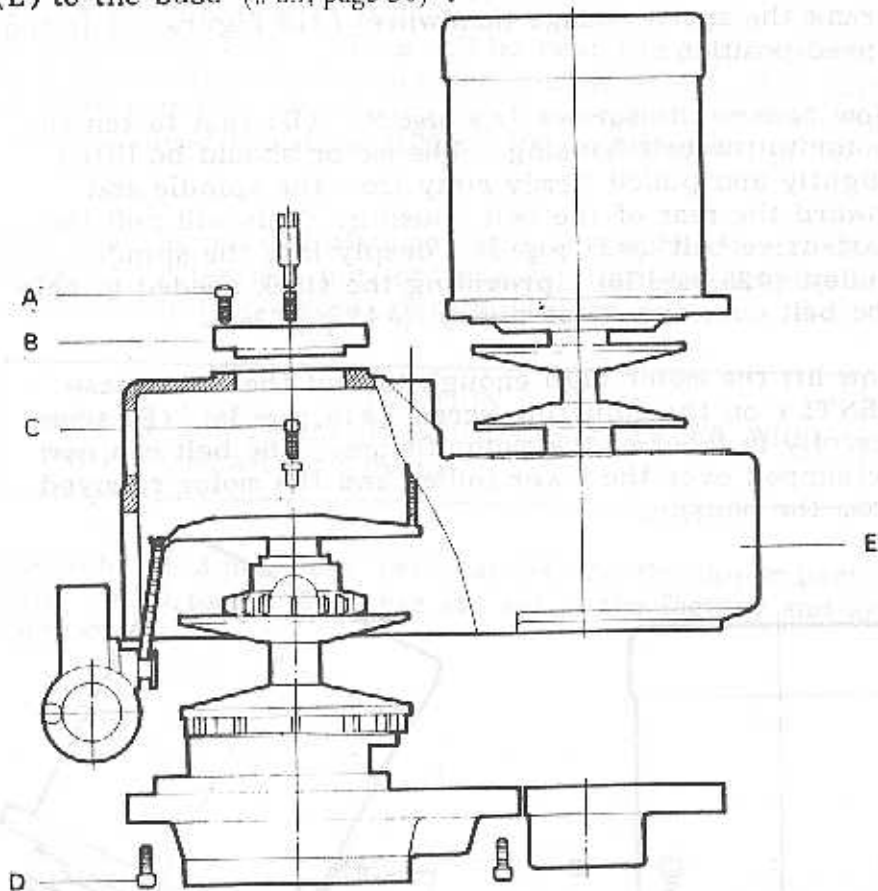

Figure 11. Removing the Vari-Drive Belt.

Remove the old belt (#27, page 36) and replace it with a new belt. Do not use a substitute belt purchased from other than Bando Variable Belt 975VC 38 x 30. Vibration and heat could result from the use of the wrong belt.

## CHANGING TIMING BELT (Figure 12)

Complete the operation for removing the motor. Then put the Hi-Neutral-Lo lever (#15, Figure 9) in the Lo position, remove the drawbar (#14, page 36) (A, Figure 12) and lower the spindle.

Remove screws (#64, page 36) (B) holding the upper and lower housings (#63, page 36) together, including the two lower screws (C) in speed changer bracket just below the speed dial.

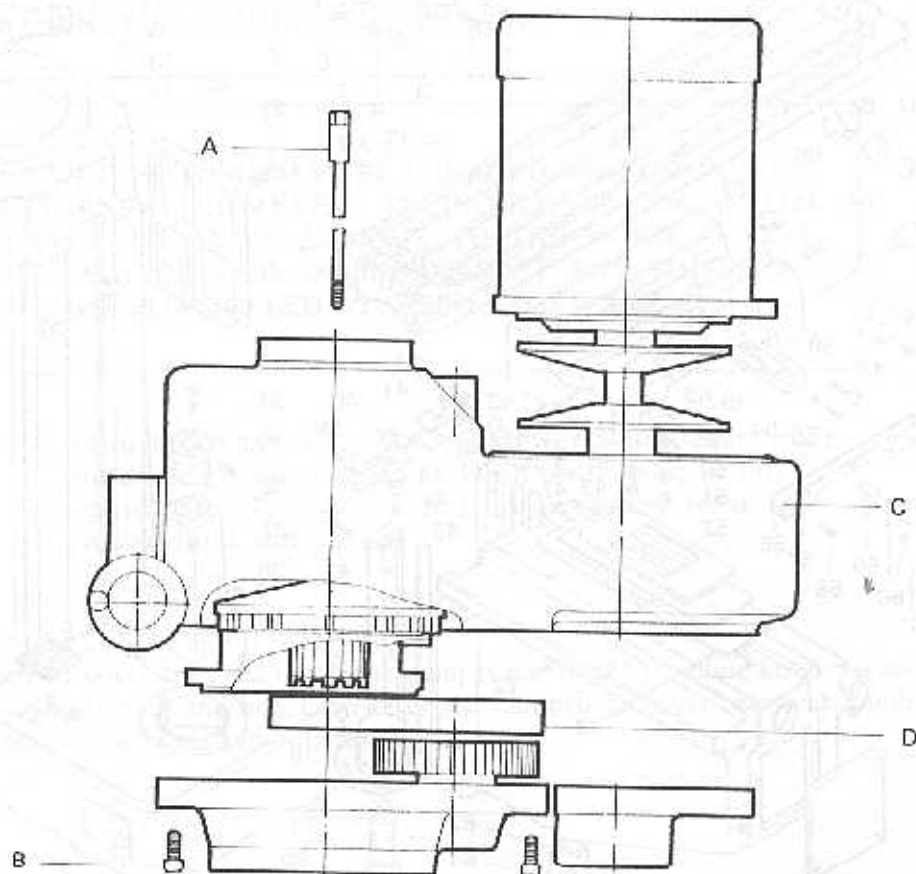
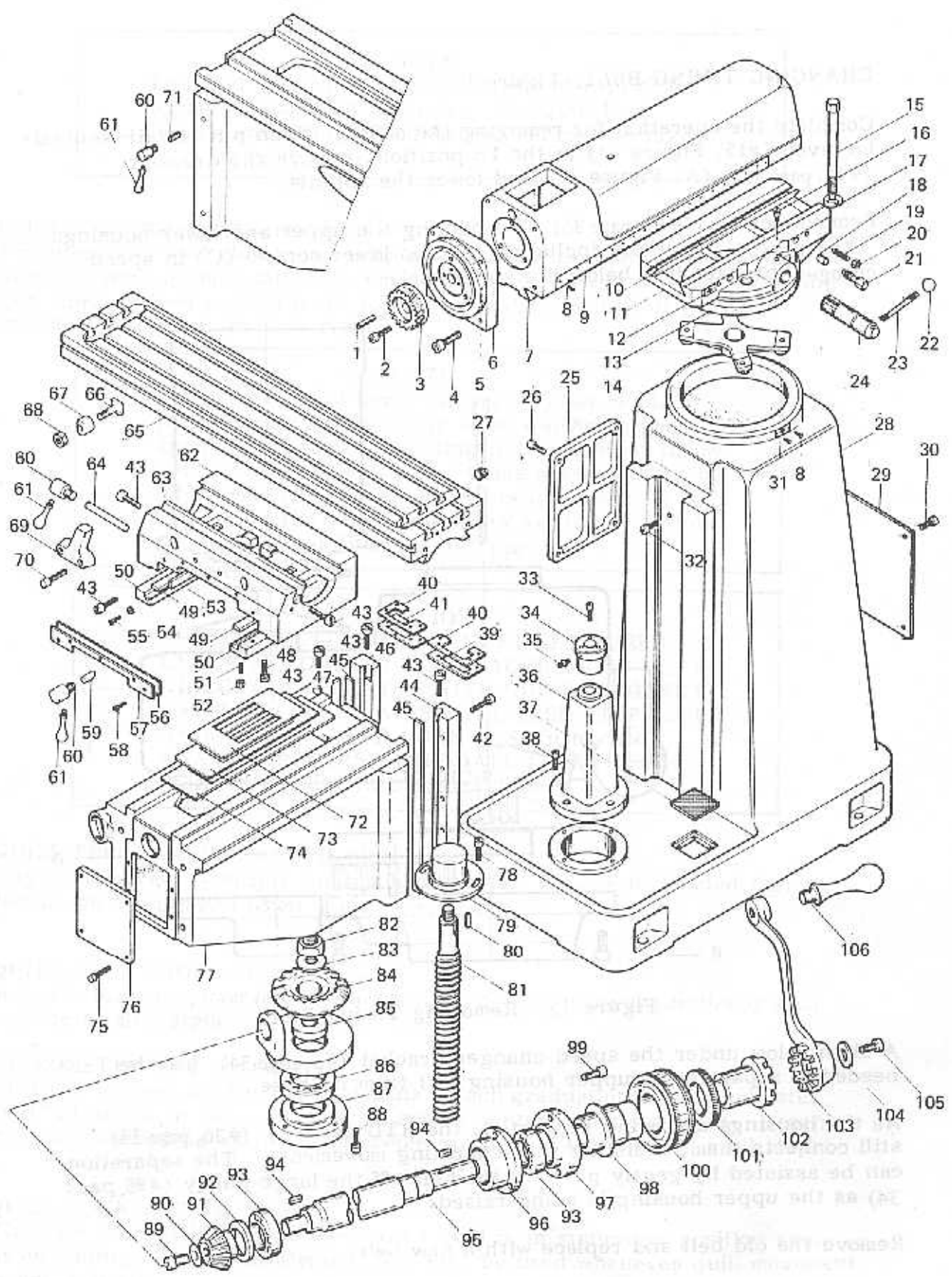

Figure 12. Removing Timing Belt

A slight blow under the speed changer bracket (#5, page 34) may be needed to separate the upper housing (D) from its base.

As the housings are being separated, the HTD belt (E) (#36, page 34) still connects them, resisting the separating movement. The separation can be assisted by gently pushing the belt off the large pulley (#86, page 34) as the upper housing is being raised.

Remove the old belt and replace with a new belt.





## BASIC MACHINE

ITEM NO.	PARTS NO.	DESCRIPTION	ITEM NO.	PARTS NO.	DESCRIPTION
1	5K-5034	Roll Pin	54	4H-3050-3	Washer (4 Req)
2	5K-5035	Socket Cap Screw (2 Req)	55	4H-3050-4	Socket Cap Screw (4 Req)
3	5K-5033	Quill Housing Adj. Gear	56	4H-3037	Felt Wipers (2 Req)
4	5K-5028	Socket Cap Screw (7 Req)	57	4H-3037-1	Saddle Knee (2 Req)
5	5K-5016	Ram Adapter Plate	58	3038	Oval Head Screw (10 Req)
6	5K-5019	Ram Adapter	59	H-3029	Table Lock Plunger (2 Req)
7	5K-5018	Ram	60	3030	Saddle Lock Bolt (5 Req)
8	5032	Round HD Drive Screw (23 Req)	61	3031	Table Lock Bolt Handle (5 Req)
9	H-5044	Ram Plate	62	4H-3001	Saddle
10	5K-5002	Ram/Turret Gib	63	3026	Saddle/Table Gib
11	5K-5001	Turret	64	4H-3032	Saddle Lock Plunger
12	5031	Plate	65	2001-50	Table-50"
13	5K-5030	Turret Plate	66	2031	Stop Piece T-Bolt (2 Req)
14	5K-5003	Spider	67	2030	Table Stop Bracket (2 Req)
15	5K-5004	Locking Bolt (4 Req)	68	2032	Hex Nut (2 Req)
16	5K-5015	Ram Pinion Screw	69	3035	Table Stop Bracket
17	5K-5005	Chamfered x Handened Washer	70	3036	Socket HD Cap Screw (2 Req)
18	H-5006	Ram Lock Plunger (2 Req)	71	4H-4043	Knee Lock Plunger (2 Req)
19	H-5007	Gib Screw (2 Req)	72	H-3040	Chip Guards
20	H-5007-1	Gib Screw Nut (2 Req)	73	H-3039-1	Chip Guards
21	H-5010	Ram Lock Stud (2 Req)	74	4H-3039	Chip Guards
22	5K-5014	Plastic Ball	75	3B-1005-1	Cap Screw (4 Req)
23	5K-5013	Ram Pinion Handle	76	3B-1005	Knee Cover
24	5K-5012	Ram Pinion	77	4H-4001	Knee
25	H-1002	Column Cover	78	4036	Socket Head Cap Screw (2 Req)
26	H-1003	Socket Head Cap Screw (4 Req)	79	4034	Bevel Gear Cover
27	2035	Plug (2 Req)	80	4020	Key
28	4H-1001	Column	81	4H-4021	Elevating Screw Assembly
29	4H-1002	Column Cover	82	4023	Jam Nut
30	4H-1003	Cap Screw (4 Req)	83	4019-1	Washer
31	5031	Plate (5 Req)	84	4019	Bevel Gear
32	4H-1001-1	Stop Screw	85	4022	Bevel Gear Spacer
33	4025	Socket Hand Cap Screw (3 Req)	86	4040	Bearing
34	4H-4024	Elevating Screw Nut	87	4039	Bearing Retainer Ring
35	4024-1	Grease Nipple	88	4041	Socket Head Cap Screw (3 Req)
36	4H-4026	Pedestal	89	4042	Socket Head Cap Screw
37	4H-1004	Filter (2 Req)	90	4017-1	Washer
38	4027	Socket Head Cap Sacrew (4 Req)	91	4014	Beyel Gear
39	4H-4028	Knee Wiper Felt	92	4014-1	Bevel Gear Spacer
40	4H-4028-2	Wiper Holder (2 Req)	93	4007	Bearing (2 Req)
41	4H-4028-1	Knee Wiper Felt	94	4015	Key (2 Req)
42	4H-4052	Socket Head Cap Screw (10 Req)	95	4H-4017	Elevating Shaft
43	3028	Gib Adj-Screw (10 Req)	96	4006	Bearing Cap
44	4H-4051	Knee/Column Gib Support	97	2011	Bearing Retaining Ring
45	4H-4053	Knee/Column Gib (2 Req)	98	4011	Dial Holder
46	4H-4050	Knee/Column Gib Support	99	4009	Socket Head Cap Sacrew (3 Req)
47	4H-4038	Knee/Column Gib	100	4010	Dial with 100 Graduation
48	4H-3052	Socket Head Cap Screw (8 Req)	101	2016	Dial Lock Nut
49	4H-3027-1	Saddle/Knee Gib (2 Req)	102	4013	Gearshaft Clutch Insert
50	4H-3050	Saddle/Table Gib Support (2 Req)	103	4002	Elevoting Crank
51	4H-3050-1	Setscrew (8 Req)	104	4004	Washer
52	4H-3050-2	Jam Nut (8 Req)	105	4005	Socket Head Cap Screw
53	4H-3027	Saddle/Knee Gib	106	4003	Handle.

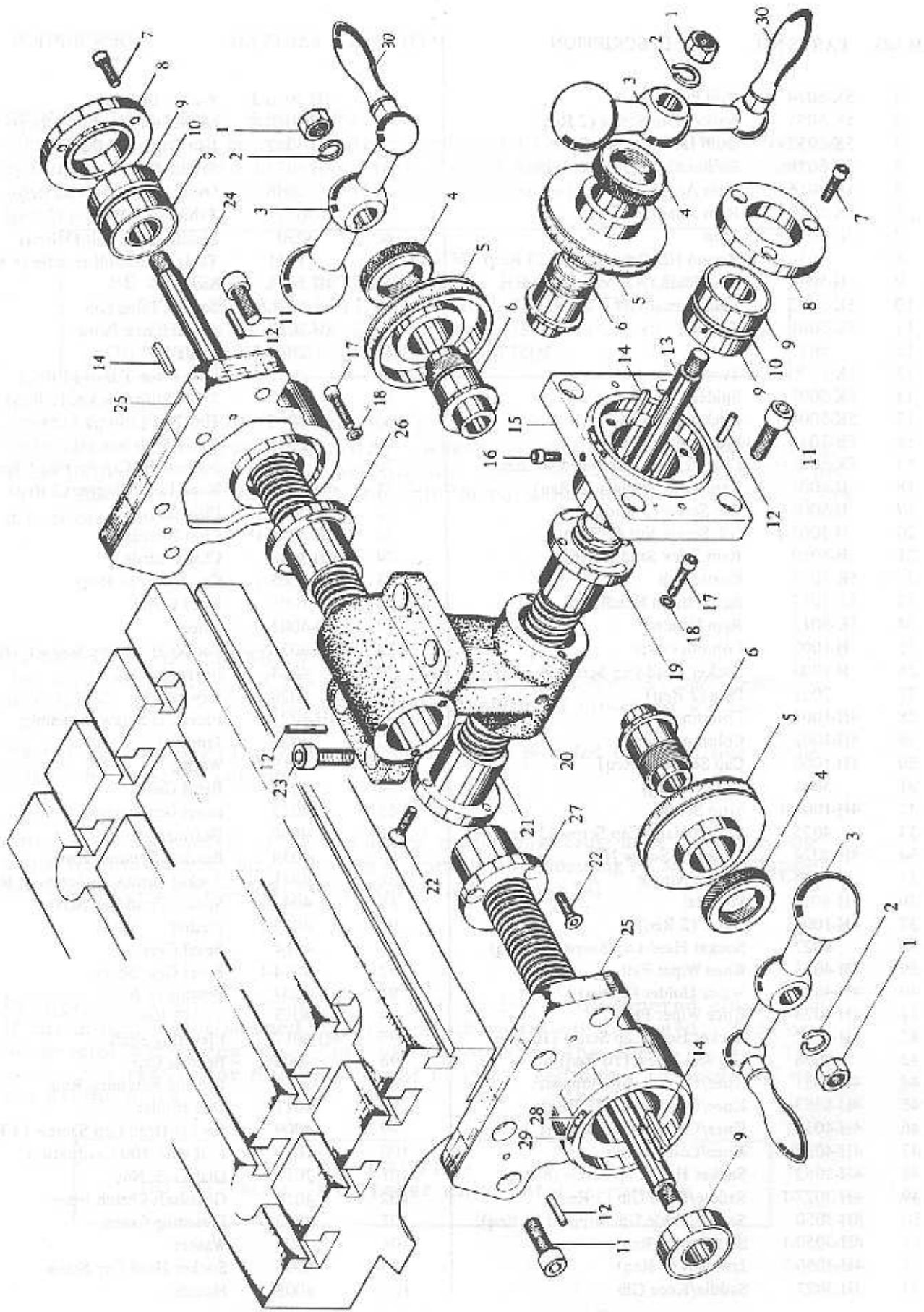

## LEADSCREW ASSEMBLY

ITEM NO.	PARTS NO.	DESCRIPTION	ITEM NO.	PARTS NO.	DESCRIPTION
1	2004	Jam Nut (3 Req.)	16	3005-1	Stop Screw (4 Req.)
2	2004-1	Spring Washer (3 Req.)	17	3025-2	Socket Screw (4 Req.)
3	H2018	Ball Crank Handle (3 Req.)	18	3025-3	Washer (4 Req.)
4	2016	Dial Lock Nut (3 Req.)	19	3020-2A	Cross Feed Nut
5	2012	Dial with 200 Graduations (3 Req.)	20	H3025	Feed Nut Bracket
6	2014	Dial Holder (3 Req.)	21	3020-2B	Cross Feed Nut
7	2036	Socket Cap Screw (6 Req.)	22	3025-1	Flat Head Socket Screw (6 Req.)
8	2011	Bearing Retainer Ring (2 Req.)	23	3024	Socket Cap Screw (4 Req.)
9	2008	Grease Seal Ball Bearing 6204# (5 Req.)	24	2002	Longitudinal Feed Screw 50°
10	2010	Washer (2 Req.)	25	2006	Bearing Bracket (2 Req.)
11	2026	Socket Cap Screw (12 Req.)	26	3020-1A	Long Feed Nut
12	2027	Roll Pin (8 Req.)	27	3020-1B	Long Feed Nut
13	H3002	Cross Feed Screw for 13 3/4" Knee	28	5016-1	Plate (3 Req.)
14	2003	Key (3 Req.)	29	5032	Round HD Drive Screw (6 Req.)
15	3005	Cross Feed Bearing Bracket	30	H2018 -1	Ball Crank Handle Grip (3 Req.)

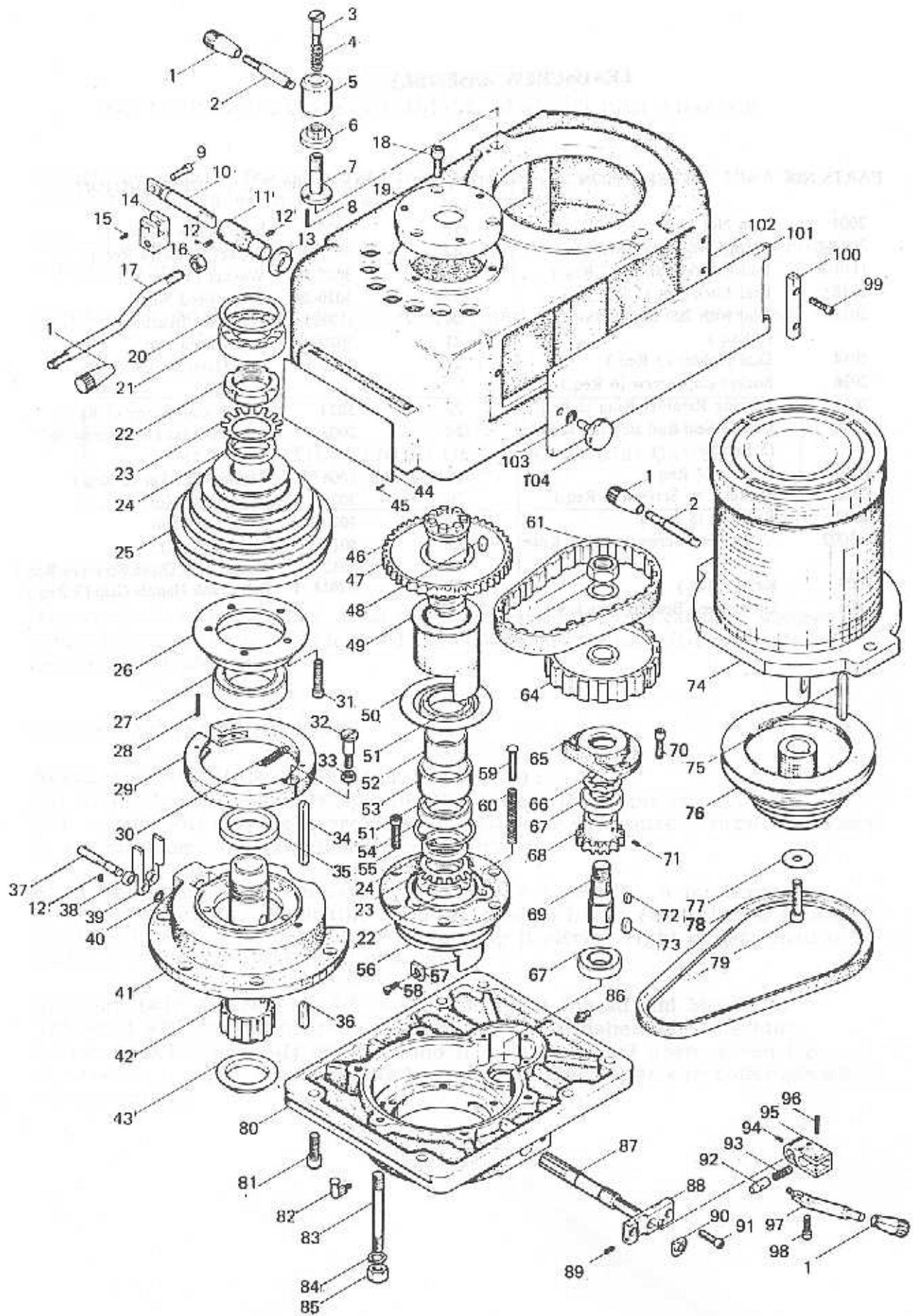

## 5K HEAD TOP HOUSING

ITEM NO.	PARTS NO.	DESCRIPTION	ITEM NO.	PARTS NO.	DESCRIPTION
1	3H-7069	Plastic Handle (5 Req)	53	5K-7043B	Ball Bearing Spacer
2	5K-6006	Motor Fix Handle (3 Req)	54	5K-7042	Snap Ring
3	5K-6005	Set Bolt (2 Req)	55	5K-7045	Socket Cap Screw (6 Req)
4	5K-6007	Spring (2 Req)	56	5K-7049	Fixed Clutch Bracket
5	5K-6004	Bolt Box Spamer (2 Req)	57	7051	Guib for Clutch Bracket (2 Req)
6	5K-6003	Fix Nut (2 Req)	58	7052	Flat HD Socket Cap Screw (2 Req)
7	5K-6002	Set Bolt (2 Req)	59	7055-1	Adjust Pin (3 Req)
8	5K-6008	Roll Pin (2 Req)	60	5K-7055	Compression Spring (3 Req)
9	5K-8072	Cap Screw	61	5K-7036	Belt
10	5K-8074	Brake Lock Shaft	62	5K-7087	Jam Nut
11	5K-8073	Sleeve for Brake Lock Shaft	63	5K-7087-1	Spring Washer
12	5K-8076	Set Screw (3 Req)	64	5K-7086	Timing Belt Pulley
13	8075	Rubbr Busing	65	5K-7084	Bull Gear Pinion Bearing
14	5K-8071	Brake Block	66	5K-7082	Wave Spring Washer
15	5K-8077	Set Screw	67	5K-7079	Ball Bearing (2 Req)
16	5K-8070-1	Jam Nut	68	5K-7083	Bull Gear Pinion
17	5K-8070	Brake Handle	69	5K-7080	Gear Shaft
18	5K-8001	Socket Cap Screw (3 Req)	70	5K-7085	Socket HD Cap Screw (3 Req)
19	5K-7013	Top Bearing Cap	71	5K-7077	Socket Set Screw
20	5K-8003	Washer	72	5K-7078	Key
21	5K-8004	Bearing	73	5K-7078-1	Key
22	5K-7056	Bearing Locknut (2 Req)	74	5K-6001	Motor SHP
23	5K-7057-1	Lock Washer (2 Req)	75	5K-6009-1	Key
24	5K-7057-2	Washer (2 Req)	76	5K-6009	Motor Pulley
25	5K-6048	Spindle Pulley	77	5K-6001-1	Pulley Washer
26	5K-8029	Brake Bearing Cap	78	5K-6034	"V" Belt
27	5K-8023	Ball Bearing	79	5K-6001-2	Socket Cap Screw
28	5K-8030	Roll Pin (4 Req)	80	5K-8063	Gear Housing
29	5K-8032	Brake Shoe Assembly	81	5K-8064	Socket Cap Screw (6 Req)
30	5K-8031	Brake Spring (2 Req)	82	5K-7054	Oil Cap (2 Req)
31	5K-8029-1	Socket HD Cap Screw (5 Req)	83	5K-7063	Socket Cap Screw (3 Req)
32	5K-8036	Brake Shoe Pivot Sleeve	84	5K-7062	Lock Washer (3 Req)
33	5K-8035	Jam Nut	85	5K-7061	Hex Nut (3 Req)
34	5K-6039	Key	86	5K-8063-1	Grease Nipple
35	5K-8033	Spindle Pulley Spacer	87	5K-7059	Bull Gear Shift Pinion
36	5K-6041	Key	88	5K-7060	Hi-Low Detent Plate
37	5K-8068-1	Brake Operating Finger	89	7064	Socket Set Screw
38	5K-8068-1	Washer	90	5K-7065	Adjustable Plate
39	5K-8067	Brake Finger Pivot Stud (2 Req)	91	5K-7068	Socket Cap Screw (2 Req)
40	5K-8066	Snap Ring	92	5K-7066	Hi-Low Detent Plunger
41	5K-8053	Belt Housing Base	93	5K-7067	Spring
42	5K-6040	Spindle Pulley Hub	94	5K-7064	Set Screw
43	5K-7038	Timing Pulley Clutch Sleeve	95	5K-7071	Hi-Low Pinion Block
44	5K-6011	Vari-Speed Dial	96	5K-7072	Roll Pin
45	5K-6011-1	Drive Screw (6 Req)	97	5K-7070	Hi-Low Shift Crank
46	5K-6075	Splined Gear Hub	98	5K-7072	Socket Cap Screw (2 Req)
47	5K-7040	Spindle Bull Gear Assembly	99	5K-6017	Socket Cap Screw (4 Req)
48	5K-7081	Key	100	5K-6015	Cover Strut (2 Req)
49	5K-7057	Bearing Sleeve	101	5K-6012	Belt Housing Cover (2 Req)
50	5K-7048	Ball Bearing Gear Sleeve Washer	102	5K-6013	Belt Housing
51	5K-7041	Ball Bearing (2 Req)	103	5K-6016	Snap Ring (2 Req)
52	5K-7043A	Ball Bearing Spacer	104	5K-6010	Cover Set Bolt (2 Req)

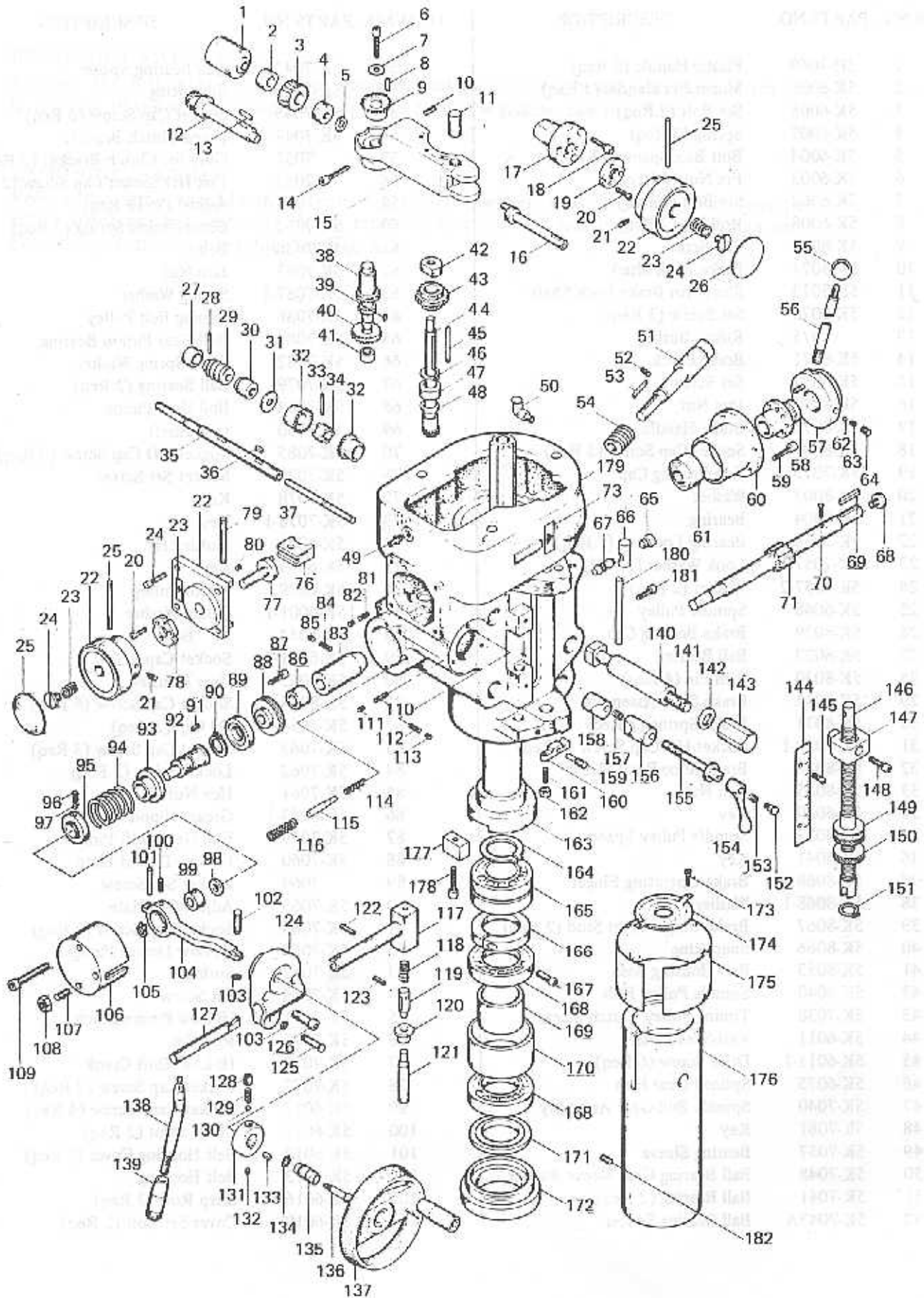

5K/5VK HEAD

ITEM NO.	PARTS NO.	DESCRIPTION	ITEM NO.	PARTS NO.	DESCRIPTION
1	5K-6137	Worm Cradle Bushing	51	5K-5040	ADJ. Worm Shaft
2	5K-6136	Worm Gear Spacer	52	5K-5042	Socket Set Screw
3	5K-6134	Feed Drive Worm Gear	53	5K-5041	Key
4	5K-6136-1	Worm Gear Bushing	54	5K-5039	Worm Gear
5	5K-6140	Snap Ring	55	5K-6173	Black Plastic Ball Handles
6	5K-6150	Cap Screw	56	5K-6174	Pinion Shaft Hub Handle
7	5K-6149	Washer	57	5K-6178	Rack Feed Handle Hub
8	5K-6147	Key	58	5K-6182	Pinion Shaft Hub Sleeve
9	5K-6148	Feed Reverse Bevel Gear	59	5K-6180-1	Cap Screw (2 Req)
10	5K-6123	Set Screw	60	5K-6180	Spring Cover
11	5K-6122	Feed Engage Pin	61	5K-6181	Clock Spring
12	5K-6139	Feed Bevel Pinion	62	5K-6176	Steel Ball
13	5K-6135	Key	63	5K-6175	Compression Spring
14	5K-6124	Cap Screw	64	5K-6177	Set Screw
15	5K-6121	Worm Gear Cradle	65	5K-6114	Reverse Trip Ball Lever Screw
16	5K-6126	Worm Gear Cradle Throw-out	66	5K-6109	Feed Reverse Trip Plunger
17	5K-6125	Shift Sleeve	67	5K-6110	Reverse Trip Ball Lever
18	5K-6132	Cap Screw (3 Req)	68	5K-6183	Pinion Shaft Hub Screw
19	5K-6127	Adj. Block	69	5K-6184	Key
20	5K-6130	Cap Screw (7 Req)	70	5K-6172-1	Cap Screw
21	5K-6169	Set Screw (2 Req)	71	5K-6172	Quill Pinion Shaft
22	5K-6168	(2 Req)	72	5K-6161	Cluster Gear Cover
23	5K-6170	Compression Spring (2 Req)	73	5K-6256-1	Plate
24	5K-6128	Spring Screw (2 Req)	74	5K-6165	Cap Screw (4 Req)
25	5K-6129	Roll Pin (2 Req)	75	5K-6256	Vari-Speed Dial
26	5K-8061	Quill Feed Nameplate	76	5K-6162	Feed Gear Shift Fork
27	5K-6227	Bushing	77	5K-6166	Cluster Gear Shift Crank
28	5K-6226	Roll Pin	78	5K-6167	ADJ. Block
29	5K-6225	Worm	79	5K-6163	Feed Shift Rod
30	5K-6224	Feed Worm Shaft Bushing	80	5K-6164	KP. Set Screw
31	5K-6223	Feed Worm Shaft Thrust Washer	81	5K-6228	Mock-it Lockscrew
32	5K-6220	Feed Reverse Bevel Gear (2 Req)	82	5K-6228-1	Socket Set Screw
33	5K-6217	Roll Pin	83	5K-6186	Quill Pinion Shaft Bushing
34	5K-6222	Feed Reverse Clutch	84	5K-6246	Lockscrew
35	5K-6209	Feed Worm Shaft	85	5K-6246-1	Socket Set Screw
36	5K-6230	Key	86	5K-6190	Pinion Shaft Worm Gear Spacer
37	5K-6216	Reverse Clutch Rod	87	5K-6189	Round Head Screw (3 Req)
38	5K-6143	Feed Driving Gear	88	5K-6187	Overload Clutch Worm Gear
39	5K-6145	Key	89	5K-6188	Overload Clutch Ring
40	5K-6144	Feed Drive Gear	90	5K-6188-1	Snap Ring
41	5K-6252	Needle Bearing	91	5K-6196	Key
42	5K-6157	Cluster Gear Shaft Upper Bearing	92	5K-6195	Overload Clutch Sleeve
43	5K-6153	Cluster Gears Assembly	93	5K-6194	Overload Clutch
44	5K-6151	Cluster Gear Shaft	94	5K-6197	Safety Clutch Spring
45	5K-6160	Cluster Gear Key	95	5K-6198	Overload Clutch Locknut
46	5K-6158	Snap Ring	96	5K-6199	Socket Set Screw
47	5K-6156	Bevel Gear Bearing	97	5K-6199-1	Brass Plug
48	5K-6159	Bevel Gear Thrust Spacer	98	5K-6201	Overload Clutch Washer
49	5K-6131	Grease Nipple	99	5K-6200	Clutch Ring
50	5K-6133	Oil Cap	100	5K-6202	Clutch Ring Pin

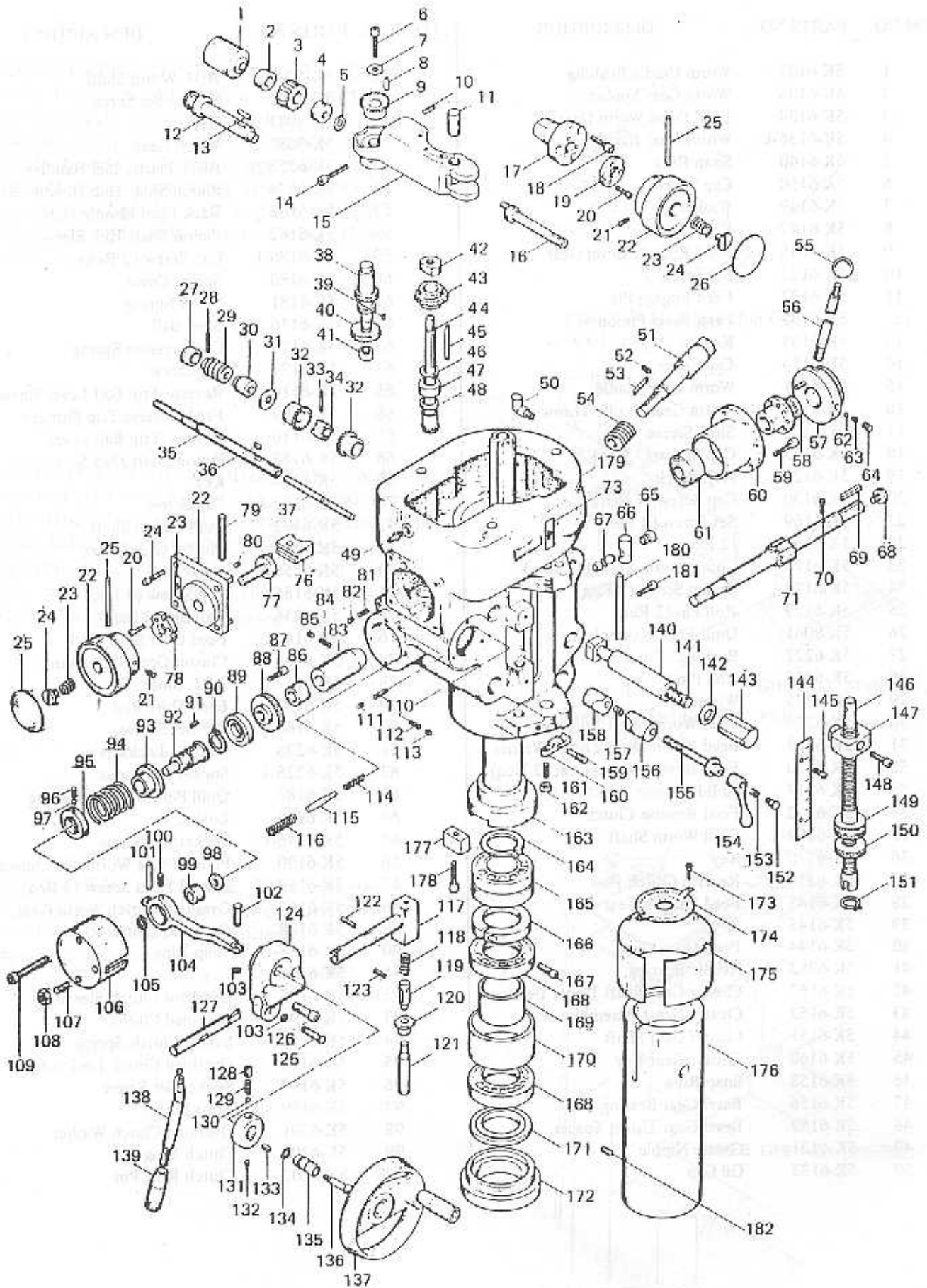



ITEM NO.	PARTS NO.	DESCRIPTION	ITEM NO.	PARTS NO.	DESCRIPTION
101	5K-6204	Pin	142	5K-5037	Spring Washer (4 Req)
102	5K-6236-1	Dowel Pin	143	5K-5038	Locknut (4 Req)
103	5K-6231-2	Snap Ring (2 Req)	144	5K-6243	Micrometer Scale
104	5K-6203	Overload Clutch Trip Lever	145	5K-6244	Chem Blacked RD. HD. Screws (2 Req)
105	5K-6195-1	Snap Ring	146	5K-6104	Quill Stop Micro-Screw
106	5K-6205	Clutch Arm Cover	147	5K-6105	Quill Stop Knob
107	5K-6207	Socket Set Screw	148	5K-6106	Screw
108	5K-6208	Chem Blacked Locknut	149	5K-6107	Micrometer Nut
109	5K-6206	Cap Screw (2 Req)	150	5K-6108	Quill Micro-stop Nut
110	5K-6228	Socket Set Screw	151	5K-6115	Snap Ring
111	5K-6228-1	Mock-it Lockscrew	152	5K-6117-2	Spring Screw
112	5K-6246	Socket Set Screw	153	5K-6117-1	Spring
113	5K-6246-1	Lockscrew	154	5K-6119	Lock Handle
114	5K-6191	Compression Spring	155	5K-6117	Quick Lock Bolt
115	5K-6193	Overload Clutch Lever Spring Plunger	156	5K-6116A	Quill Lock Sleeve Tapped
116	5K-6192	Compression Spring	157	5K-6116-1	Compression Spring
117	5K-6236	Cam Rod Sleeve Assy	158	5K-6116B	Quill Lock Sleeve
118	5K-6242	Compression Spring	159	5K-6112	Trip Lever Pin
119	5K-6240	Trip Plunger	160	5K-6111	Feed Trip Lever
120	5K-6118-1	Trip Plunger Bushing	161	5K-6113	Socket Set Screw
121	5K-6118	Feed Trip Plunger	162	5K-6113-1	Chem Blacked Locknut
122	5K-6237	Roll Pin	163	5K-6084	Spindle 40*
123	5K-6241	Roll Rin	164	5K-6090	Snap Ring
124	5K-6231	Feed Trip Bracket	165	5K-6092	Bearing (2 Req)
125	5K-6231-1	Dowel Pin	166	5K-6094	Nut
126	5K-6232	Cap Screw (2 Req)	167	5K-6094-1	Cap Screw
127	5K-6239	Cam Rod	168	5K-6093	Bearing (2 Req)
128	5K-6219-1	Handwheel Clutch Spring Screw	169	5K-6096	Bearing Spacer-Small
129	5K-6219-2	Compression Spring	170	5K-6095	Bearing Spacer-Large
130	5K-6255	Steel Ball	171	5K-6097	Spindle Dirt Shield
131	5K-6218	Handwheel Clutch	172	5K-6098	Nose Piece
132	5K-6219	Socket Set Screw	173	5K-6088-1	Felt Washer Screw (2 Req)
133	5K-6229	Key	174	5K-6088	Felt Washer
134	5K-6215	Snap Ring	175	5K-6086	Quill Skirt
135	5K-6213	Reverse Knop	176	5K-6085	Quill
136	5K-6214	Feed Reverse Knob Stud	177	5K-6099	Keeper Key
137	5K-6210	Handwheel	178	5K-6100	Cap Screw
138	5K-6234	Trip Handle	179	5K-6101	Quill Housing
139	3H-7069	Plastic Handle	180	5K-6251	Set Bar
140	5K-6120	Lower Clamping Bolt Spacer (2 Req)	181	5K-6253	Cap Screw
141	5K-5036	T-Bolt Assy (4 Req)	182	5K-6085-1	Set Screw

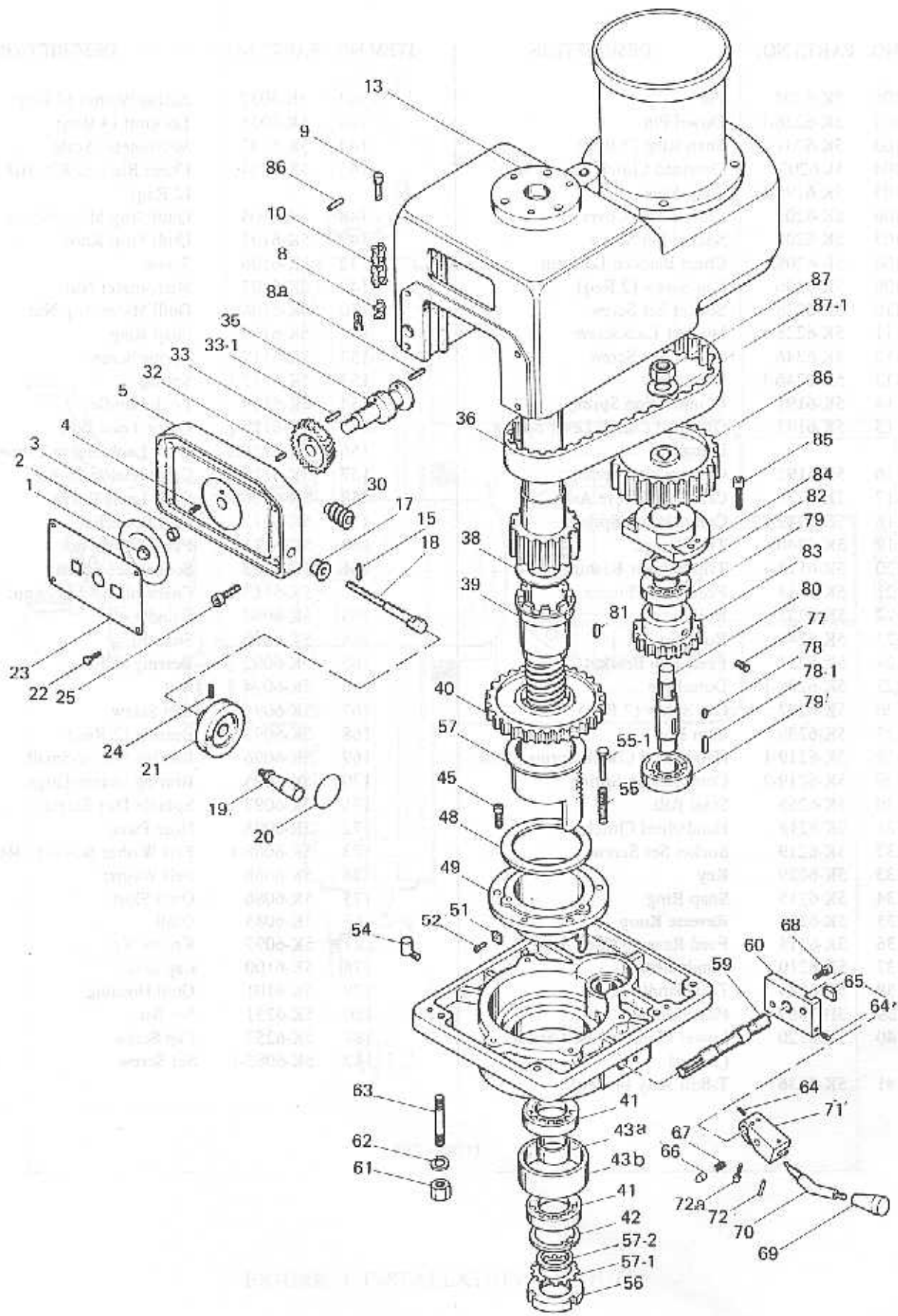

## 5 BVK VARI-SPEED HEAD TOP HOUSING

ITEM NO.	PARTS NO.	DESCRIPTION	ITEM NO.	PARTS NO.	DESCRIPTION
1	5K-7001	Hex Cap Nut			
2	5K-7002	Vari-Speed Dial	54	7054	Oil Cup
3	5K-7001-1	Bronze Bearing	55	5K-7055	Compression Spring (3 Req.)
4	5K-7004	Full Dog Socket Set Screw	55-1	7055-1	Adjust Pin (3 Req.)
5	5K-7005	Speed Changer Housing	56	5K-7056	Bearing Locknut
8	7008	Chain Joint	57	5K-7057	Bearing Sleeve
8a	7008a	Roll Pin	57-1	5K-7057-1	Lock Washer
8b	7008b	Roll Pin	57-2	5K-7057-2	Washer
9	5K-7009	Speed Change Stud	59	5K-7059	Bull Gear Shift Pinion
10	7010	Speed Change Chain	60	5K-7060	Hi-Low Detent Plate
13	5K-7013	Top Bearing Cap	61	5K-7061	Hex Nut (3 Req.)
15	5K-7015	Roll Pin	62	5K-7062	Lock Washer (3 Req.)
17	5K-7017	Bronze Bearing	63	5K-7063	Socket Cap Screw (3 Req.)
18	5K-7018	Speed Change Shaft	64	7064	Socket Set Screw (2 Req.)
19	5K-7019	Handle	65	5K-7065	Adjustable Plate
20	7020	Caution Plate	66	5K-7066	Hi-Low Detent Plunger
21	5K-7021	Speed Change Handwheel	67	5K-7067	Spring
22	7022	Flat HD. Cap Screw (4 Req.)	68	5K-7068	Socket Cap Screw (2 Req.)
23	5K-7023	Face Plate	69	5K-7069	Bakelite Ball Handle
24	5K-7024	Set Screw	70	5K-7070	Hi-Low Shift Crank
25	5K-7025	Socket HD Cap Screw (4 Req.)	71	5K-7071	Hi-Low Pinion Block
30	5K-7030	Worm Gear	72	5K-7072	Roll Pin
32	5K-7032	Set Screw (2 Req.)	72a	5K-7072a	Socket Cap Screw
33	5K-7033	Speed Changer Spur Gear	77	5K-7077	Socket Set Screw
33-1	5K7033-1	Roll Pin	78	5K-7078	Key
35	5K-7035	Speed Change Chain Drum	78-1	5K-7078-1	Key
36	5K-7036	Belt	79	5K-7079	Ball Bearing (2 Req.)
38	5K-7038	Timing Pulley Church Sleeve	80	5K-7080	Gear Shaft
39	5k-7039	Spline Gear Hub	81	5K-7081	Key
40	5K-7040	Spindle Bull Gear Assembly	82	5K-7082	Wave Spring Washer
41	5K-7041	Ball Bearing (2 Req.)	83	5K-7083	Bull Gear Pinion
42	5K-7042	Snap Ring	84	5K-7084	Bull Gear Pinion Bearing
43	5K-7043	Ball Gear Bearing Spacer	85	5K-7085	Socket HD Cap Screw (2 Req.)
45	5K-7045	Socket Cap Screw (6 Req.)	86	5K-7086	Timing Belt Pulley
48	5K-7048	Ball Bearing Gear Sleeve Washer	87	5K-7087	Jam Nut
49	5K-7049	Fixed Clutch Bracket	87-1	5K-7087-1	Spring Washer
51	5K-7051	Guide for Clutch Bracket (2 Req.)			
52	7052	Flat HD Socket Cap Screw (2 Req.)			

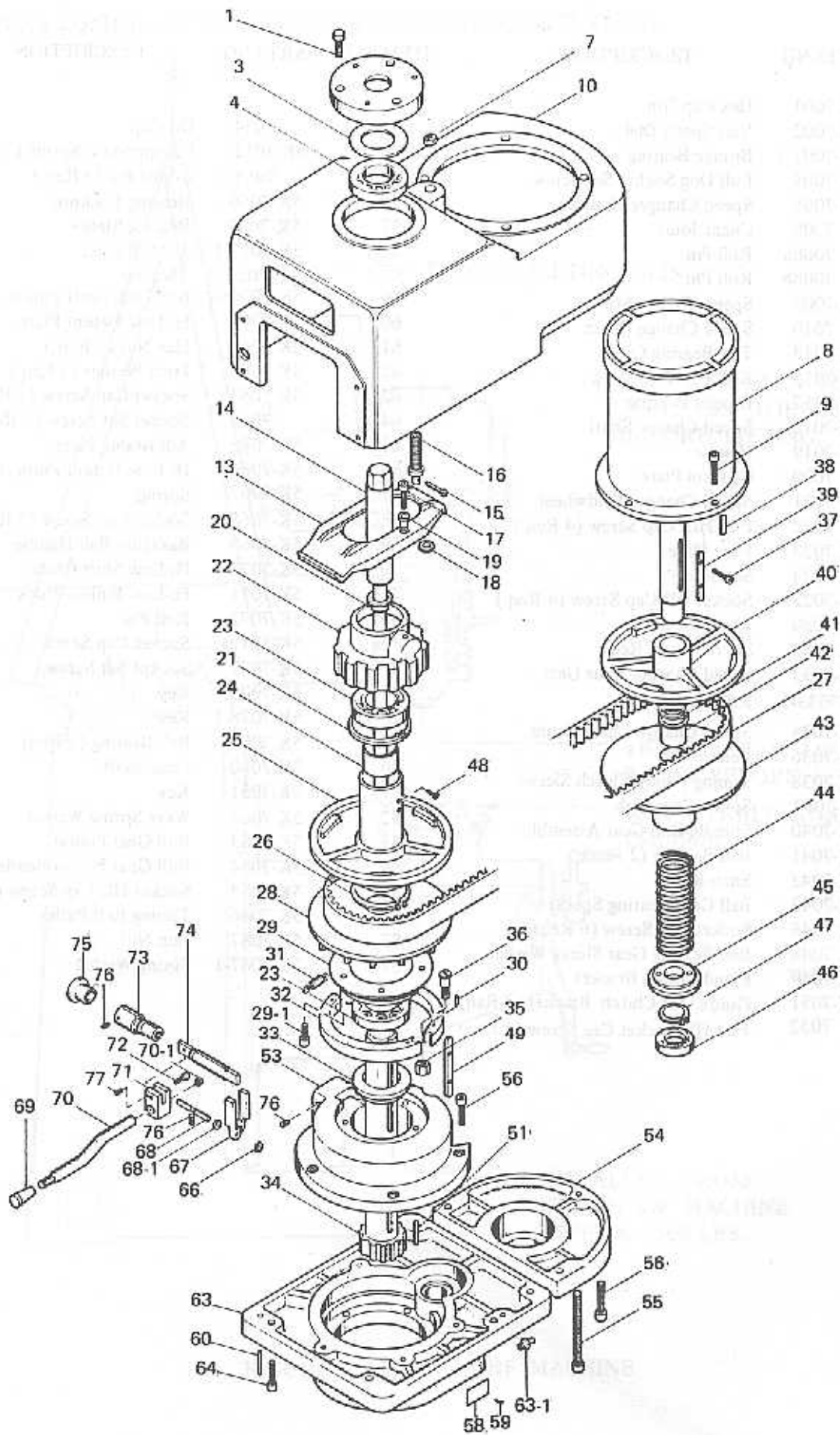

## 5 BVK VARI-SPEED HEAD 'BACK GEAR

ITEM NO.	PARTS NO.	DESCRIPTION	ITEM NO.	PARTS NO.	DESCRIPTION
1	5K-8001	Socket Cap Screw	41	5K-8041	RET. Ring
3	5K-8003	Spring Washer	42	5K-8042	Plastic Insert (2 Req)
4	5K-8004	Ball Bearing	43	5K-8043	Adjustable Motor Varidisc Assembly
7	5K-8007	Hex Jam Nut	44	5K-8044	Spring for Varidisc Motor Shaft
8	5K-8008	Motor 5HP	45	5K-8045	Adjustable Varidisc Spring Collar
9	5K-8009	Hex HD Screw (4 Req)	46	5K-8046	Ball Bearing
10	5K-8010	Belt Housing	47	5K-8047	RET. Ring
13	5K-8013	Speed Change Plate	48	5K-8048	Socket Cap Screw (2 Req)
14	5K-8014	Drawbar	49	5K-8049	Key
15	5K-8015	Cotter Pin	51	5K-8051	Key
16	5K-8016	Speed Change Plate Pivot Stud	53	5K-8053	Belt Housing Base
17	5K-8017	Socket HD Screw (2 Req)	54	5K-8054	Motor Pulley Cover
18	5K-8018	Washer	55	5K-8055	Socket Cap Screw (2 Req)
19	5K-8019	Pivot Sleeve (2 Req)	56	5K-8056	Socket Cap Screw (2 Req)
20	5K-8020	Draw Bar Washer	58	5K-8058	Hi-Low Range Nameplate
21	5K-8021	Snap Ring (2 Req)	59	5K-8059	Drive Screw (2 Req)
22	5K-8022	Spindle Pulley Bearing Sliding Housing	60	5K-8060	Taper Pin (2 Req)
23	5K-8023	Ball Bearing (2 Req)	63	5K-8063	Gear Housing
24	5K-8024	Plastic Insert (2 Req)	63-1	5K8063-1	Grease Nipple
25	5K-8025	Adjustable-Driven Varidisc	64	5K-8064	Socket Cap Screw (6 Req)
26	5K-8026	Snap Ring No.	66	5K-8066	Snap Ring
27	5K-8027	Belt	67	5K-8067	Brake Finger Pivot Stud (2 Req)
28	5K-8028	Stationary Driven Varidisc	68	5K-8068	Brake Operating Finger
29	5K-8029	Brake Bearing Cap	68-1	5K-8068-1	Washer
29-1	8029-1	Socket HD Cap Screw (5 Req)	69	3H-7069	Bakelite Ball Handle
31	5K-8031	Brake Spring (2 Req)	70	5K-8070	Brake Lock Handle
32	5K-8032	Brake Shoe Assembly	70-1	5K-8070-1	Jam Nut
33	5K-8033	Spindle Pulley Spacer	71	5K-8071	Brake Lock Handle
34	5K-8034	Spindle Pulley Hub	72	5K-8072	Socket Set Screw
35	5K-8035	Jam Nut	73	5K-8073	Sleeve for Brake Lock Shaft
36	5K-8036	Brake Shoe Pivot Sleeve	74	5K-8074	Brake Lock Shaft
37	5K-8037	Socket Cap Screw (2 Req)	75	5K-8075	Rubber Busing
38	5K-8038	Drive Key	76	5K8076	Set Scower (3 Req)
39	5K-8039	Key	77	5K-8077	Set Scower
40	5K-8040	Stationary Motor Varidisc			

# CENTRAL LUBRICATING OIL-FEEDING EQUIPMENT

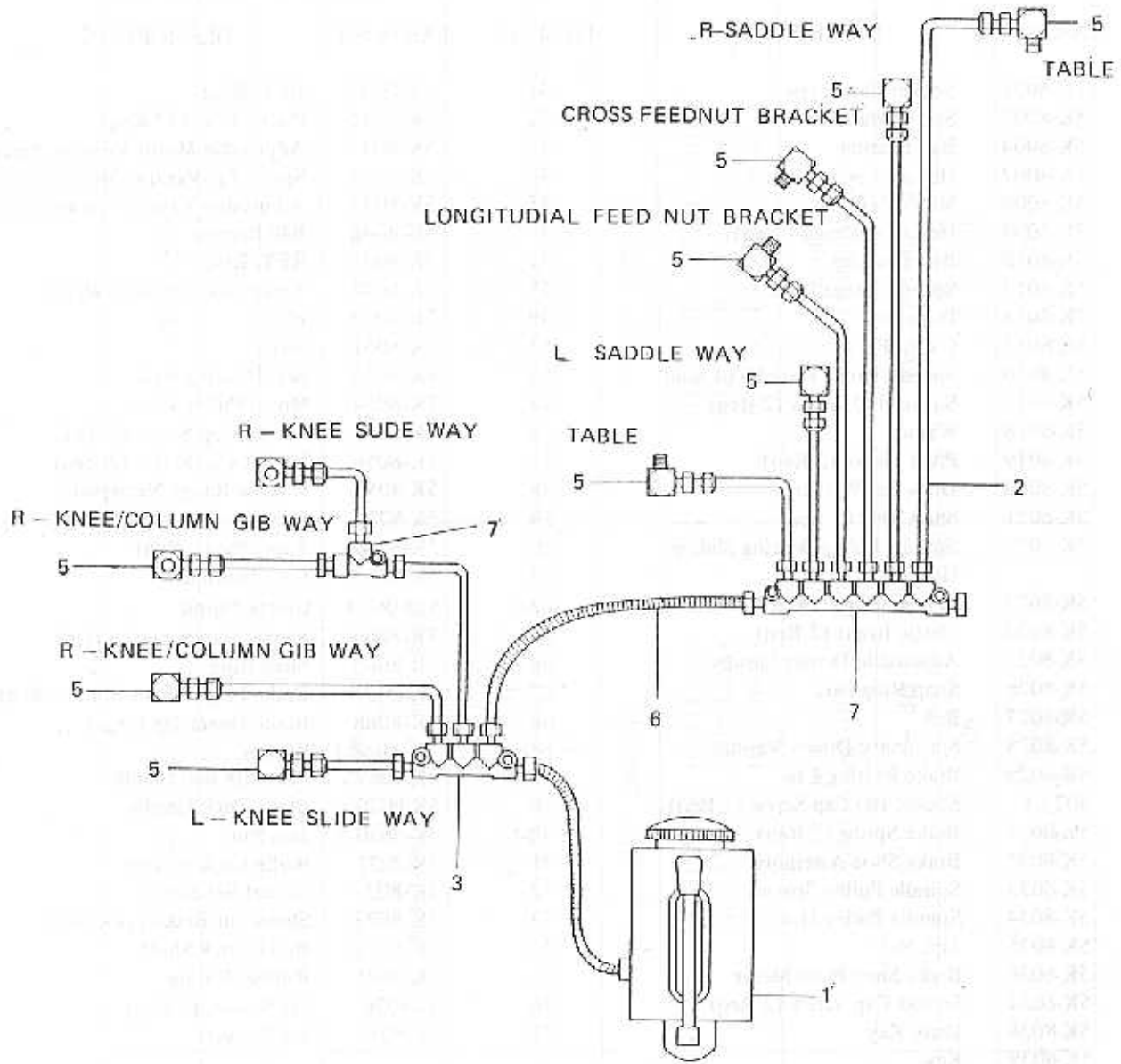

ITEMNO	PARTSNO	DESCRIPTION
1	9001	HAND OILER
2	9002	ALUMINUM PIPE
3	9003	JOINT
4	9004	JOINT
5	9005	ELOBOW JOINT
6	9006	OIL REGULATING DISTRIBUTOR
7	9007	JOINT