

POWER UNIT INSTALLATION

IMPORTANT: Disconnect electrical power to machine!

Remove the old manual drawbar and spacer (where applicable) from milling machine. Inspect the top of spindle with a flashlight for damage.

IMPORTANT: Make sure quill is fully retracted (UP) and locked. On CNC machines, move the quill up to the normal Z-home position. Insert the spline head drawbar with the new spacer for proper drawbar length. (See figure #1) Note: ALL MACHINE PARTS INC. stocks drawbars for most standard milling machines. To order, specify make and model of milling machine.

After drawbar is installed to the proper distance (See figure#1), remove and grease spline head, spacer, and threads of drawbar and reinstall.

Place the power unit on the bearing cap of machine. Align the 3 mounting holes of the power unit with the existing lift holes in bearing cap. Using the (3) 1/4-20 x3/4 SHCS mount the power unit to the bearing cap. Some bearing caps only have (2) lift holes. Torque-Rite's base plate has mounting holes to accommodate. (See figure #2).

IMPORTS: Without lift holes-Power unit can be mounted by removing the (3) bolts that hold down the bearing cap. Place the power unit on top of the bearing cap and install using the longer 6MM SHCS that are provided. (See figure #3).

On some imports and larger milling machines, the bearing cap will have to be drilled and tapped. (See figure#4).

Note: Torque-Rite's base plate can be turned in 90 degree increments by removing the base plate from the power unit and turning. (See figure #4).

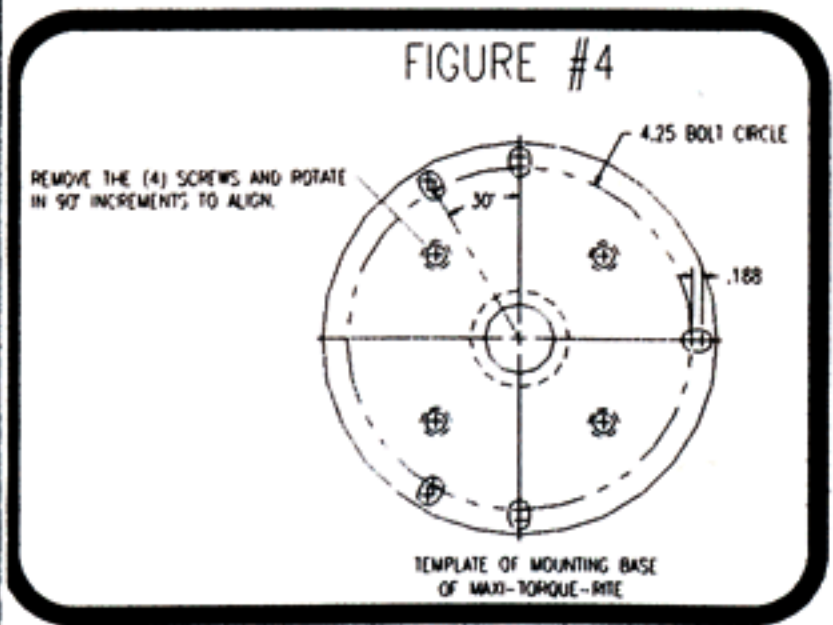
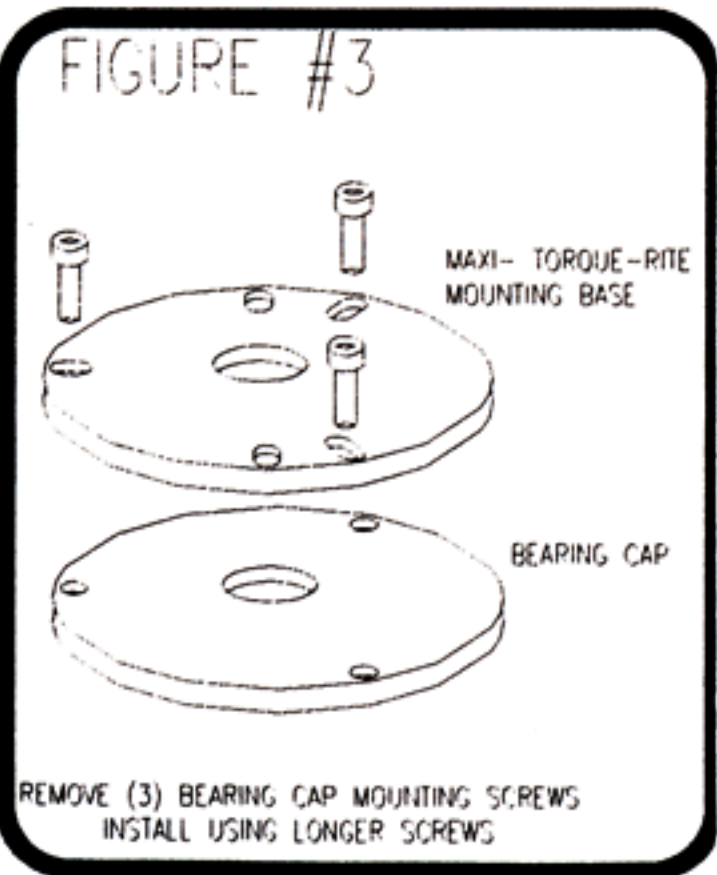
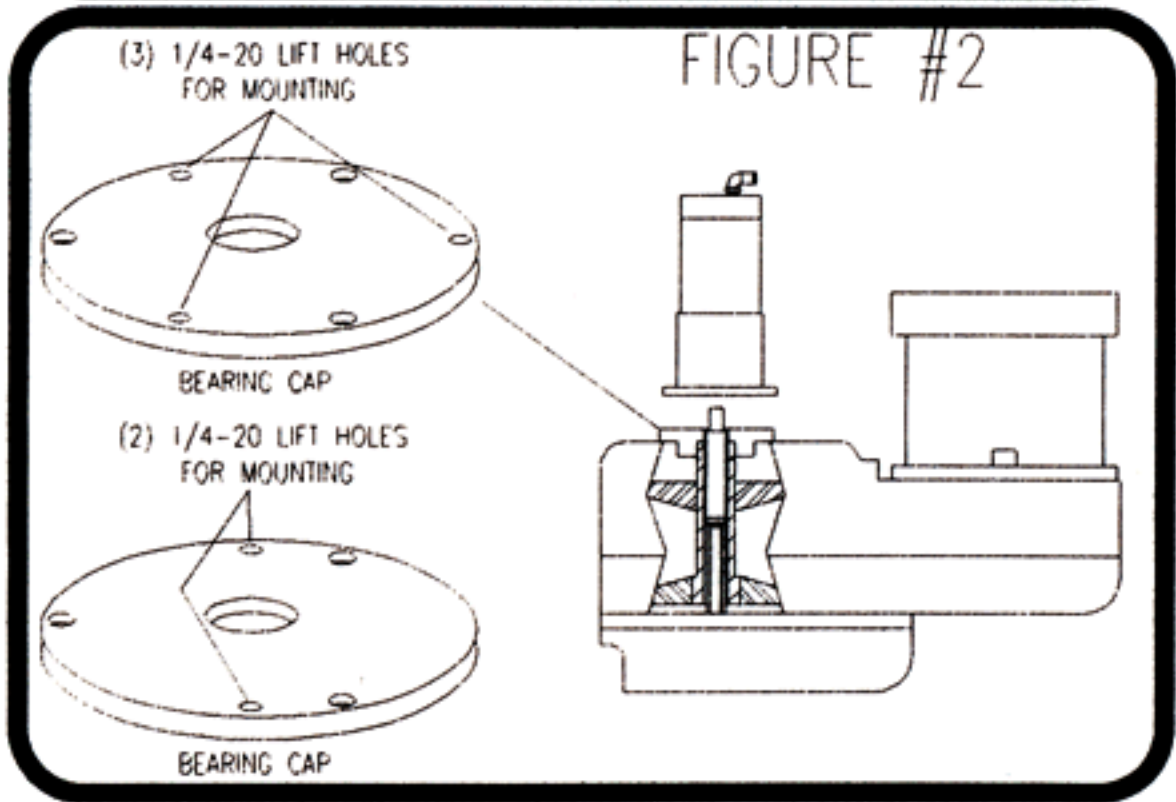
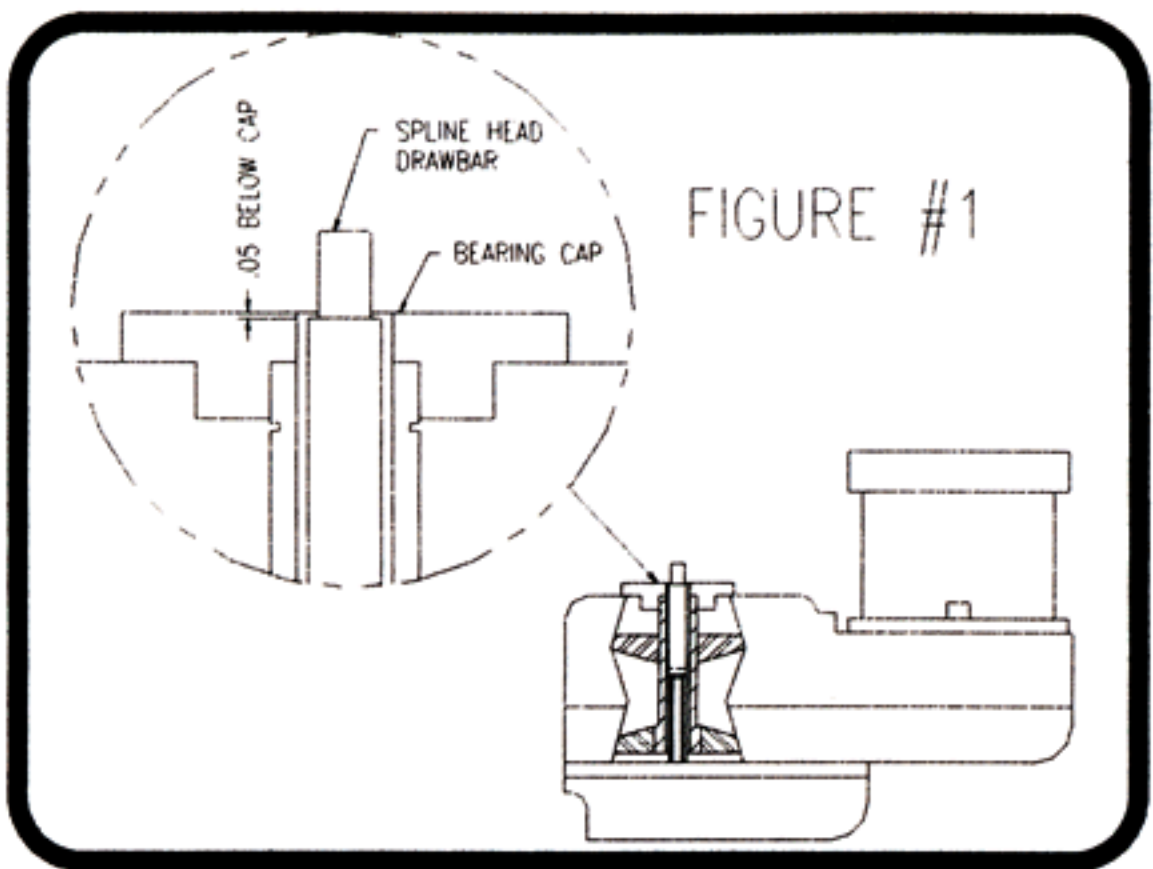

MOUNTING THE CONTROL HEAD

Remove the top (2) SHCS from the cluster gear cover. Mount control bracket using the longer 10-24 SHCS that are provided. (See figure #5).

Note: On some import machines the control bracket must be turned 90 degrees for different mounting. (See figure #6). Mount the bracket using 5MM SHCS that are provided.

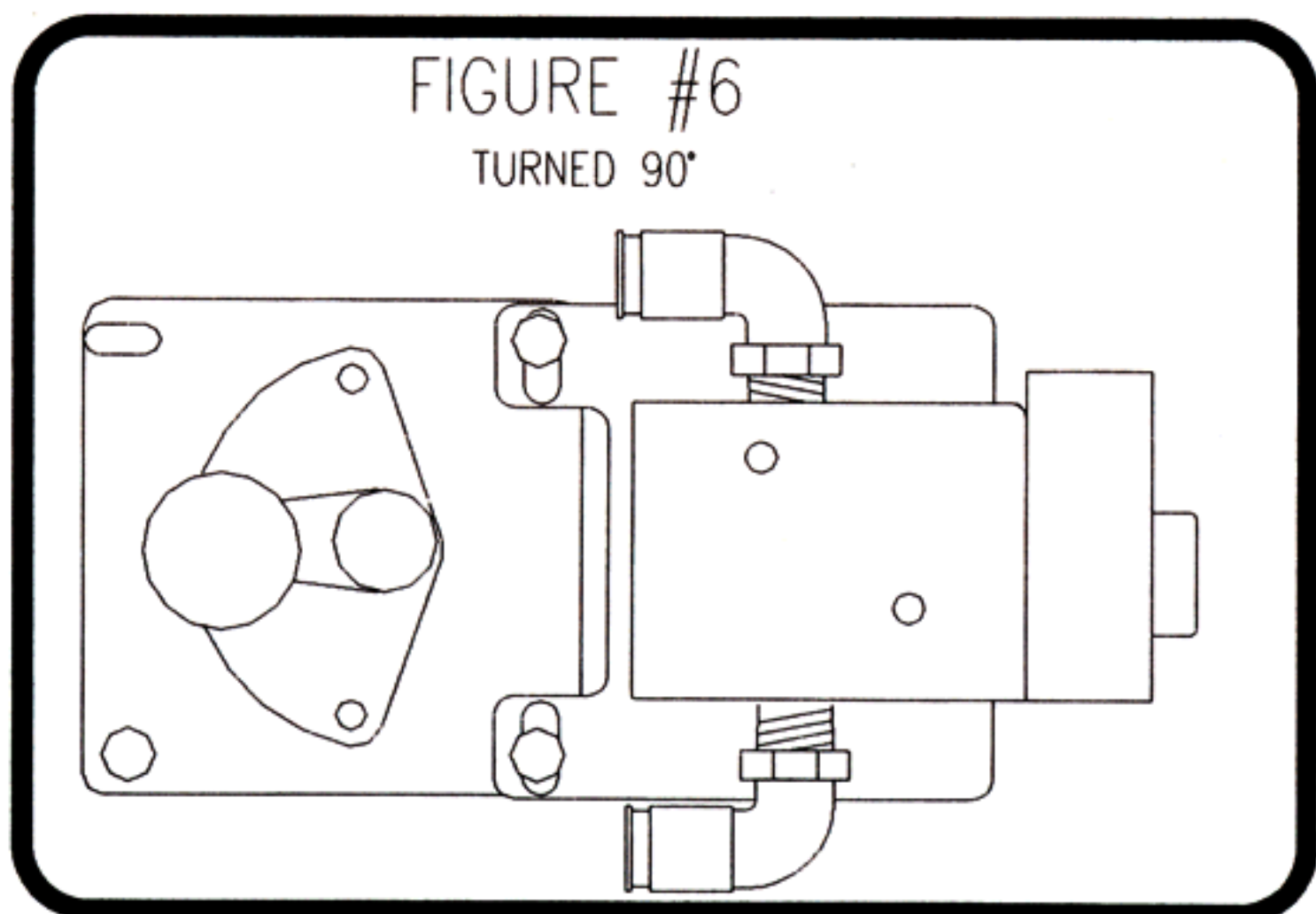
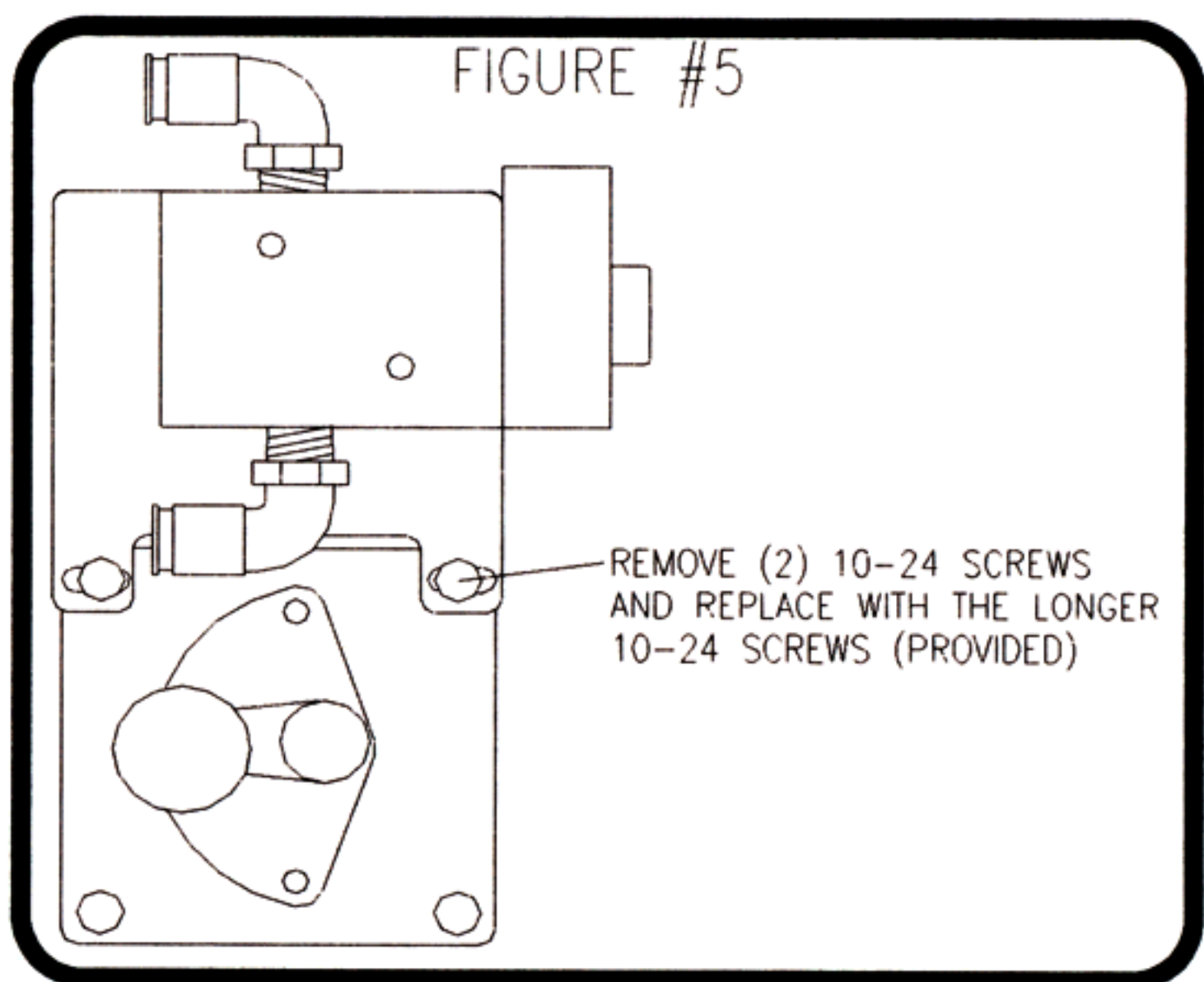

AIRLINE HOOKUP

Note: Maxi-Torque Rite is supplied with 10' of air line so that it can be tailored to your machine.

1. Start with IN and OUT connections from control head to power unit (See figure #7). Measure to proper length and cut 2 pieces of air line.
2. Oil each end of air line.
3. Firmly push air line into fitting until air line seats.
4. The remaining air line will connect the control head to the filter, regulator, lubricator unit.
5. Push air line into the remaining fitting on the control head **BOTTOM**. Feed the air line to the back of machine.

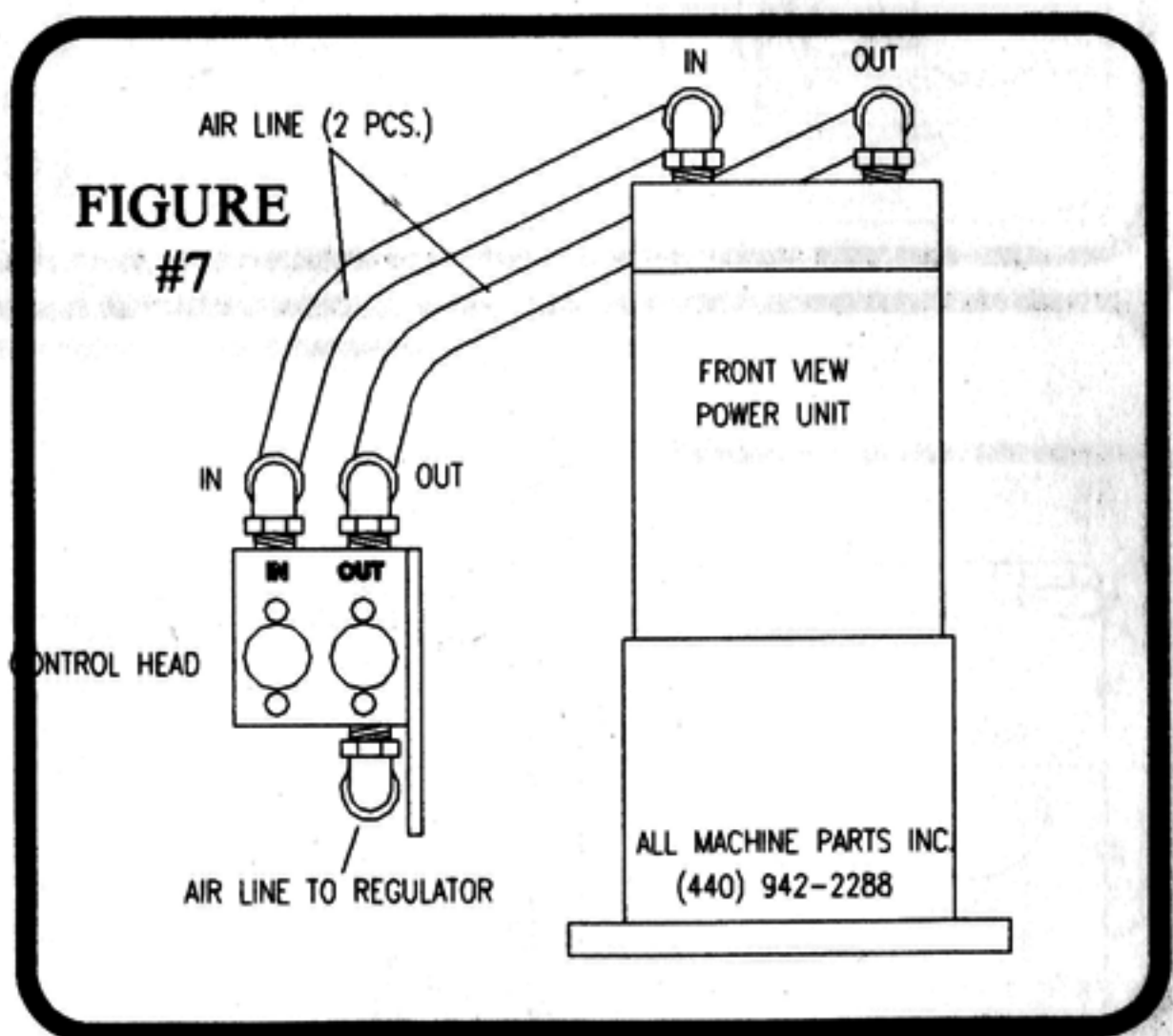

MOUNTING THE FILTER, REGULATOR, LUBRICATOR UNIT (F.R.L. UNIT)

1. Figure out a good place to mount the F.R.L. unit, keeping in mind the length of air line and the discharge of water from draining the water trap. (Usually on machine base or ram). **Note:** On a C.N.C. machine where the head moves up and down on the Z-axis, there must be a loop in the air line to compensate for up and down movement of the head. (See figure #8).
2. Drill and tap (2) 8-32 holes using F.R.L. unit as a template. Mount the F.R.L. unit with the (2) 8-32 SHCS that are provided. Connect the air line from the control head to the F.R.L. unit.
3. Supply shop air to the F.R.L. unit. Set the pressure at 90 psi on the regulator. (The pressure can be adjusted down if the drawbar unit feels to strong). Quick connect fittings work well for this application. **Note:** If more airline is needed, contact your local hose/tubing distributor or contact ALL MACHINE PARTS, INC. ask for 3/8 O.D. tubing.

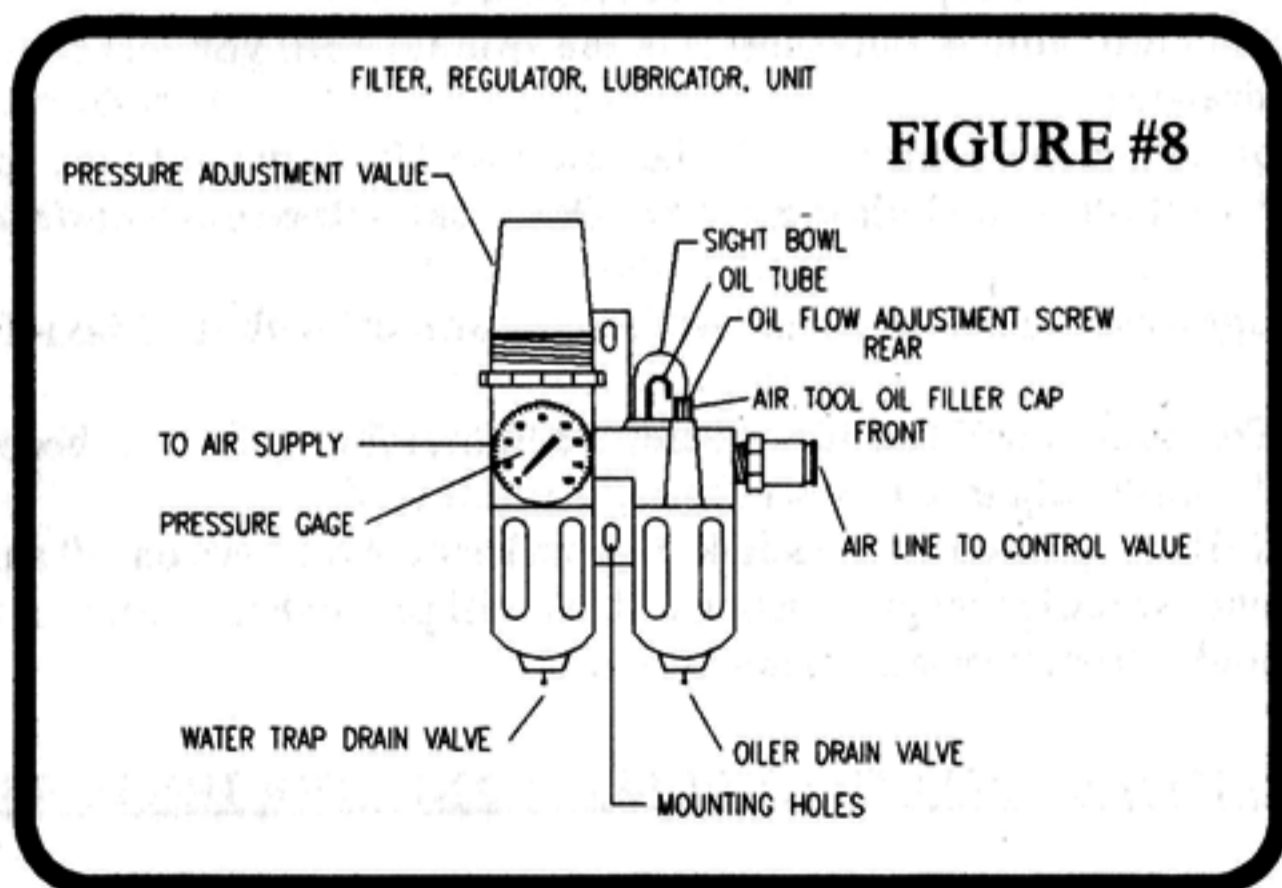

PRIMING THE OILER

After installation is complete on the Maxi-Torque Rite unit

1. With NO AIR PRESSURE on the system, remove air tool oil filler cap on top of the lubricator. Fill reservoir about 2/3 full using AIR TOOL OIL ONLY.
Replace cap.
2. Hook air supply back up to system and set regulator to 90 PSI.
3. With small flat screwdriver open (C.C.W.) oil flow adjustment screw (2) turns. (See drawing on previous page).
4. Lower the quill approx. 2" and lock the quill. Press IN and OUT button on control head in small (1 second) bursts until oil is seen dripping from the oil tube in the site bowl located on the top of the lubricator. After about (7) drops of oil stop.
5. Close (C.W.) oil flow adjustment screw. (DON'T OVER TIGHTEN).
6. Open (C.C.W.) oil flow adjustment screw 1/2 to 3/4 of a turn. Fine adjustment may be needed later.

2 to 4 Drops per day- light usage.

3 to 5 Drops per day- medium usage.

4 to 6 Drops per day- heavy usage.

OPERATION

1. Turn spindle off and apply brake until spindle stops.
2. Retract quill back to UP position. " LOCK QUILL."
3. Take collet or tool holder and insert into the spindle until you feel contact with the drawbar.
4. Push IN button on the control head. The collet will be drawn into the spindle.
5. Push OUT button while holding collet. The collet will be pushed out of the spindle.
6. Repeat steps 4 and 5 a few times to familiarize yourself with the Maxi-Torque Rite.

Note: The longer the IN button is held, the tighter the collet will become. (Usually requires 1/2 to 1 1/2 seconds).

Note: Collet alignment screws in R-8 spindles or drive keys on 30 and 40 taper spindles must be in place. This will prevent the collet or tool holder from turning during operation.

TIPS TO PREVENT STICKY COLLETS AND TOOL HOLDERS

1. Do not leave collet or tool holder in the spindle overnight.
2. Clean all nicks, dirt, oil, and heavy tarnish off collet or tool holders.
3. Inspect inside of spindle taper for nicks, dirt, oil, and heavy tarnish build-up caused by coolants and oils.
4. **Do not** over tighten the collet or tool holder.

TROUBLE-SHOOTING GUIDE

Problem: Power head goes up and down and air motor is running but the drawbar doesn't tighten or loosen.

Solution: 1. Make sure quill is all the way retracted and locked.
2. Check drawbar for proper fit. (See drawbar instructions).

Problem: Power head runs sluggish.

Solution: Too much oil: (Signs) Power head blowing heavy oil mist out of exhaust on operation. Correct by adjusting lubricator to minimum oil flow. Drop quill down approx. 2" so power head can't make contact with drawbar. Run power head until heavy oil mist stops. (See lubricator adjustment section).

Problem: Drawbar rattles when spindle is running and quill is in up position.

Solution: 1. Check for proper drawbar fit. (See drawbar section)
2. Loosen power head base from bearing cap and move slightly to center power head to drawbar.
3. Check top of spindle for wear or damage.

Problem: Drawbar stripping threads.

Solution: 1. Collet or tool holder sticking in spindle taper. Quill is being pushed down instead of collet or tool holder coming out of spindle when pushing OUT button. (See sticky collet section).
2. Inserting double ended mills too far into collet or tool holder and cutting end of drawbar with end mill.
3. Check collet or tool holder for bad threads or chips in threads.

UNIVERSAL DRAWBAR INSTRUCTIONS

Retract the quill all the way up and lock the quill. (For C.N.C. mills, move the quill to the normal Z-axis home position).

Line A: Remove old drawbar and spacer. Depth mic from top of bearing cap to the top of spindle and subtract $.050 + .025 - .0$ this is dimension. (See figure #9). **A=** _____

-OR-

Line A: Scribe a line on the old drawbar even with the top of bearing cap. Remove old drawbar with the spacer and measure from the bottom of the spacer to the scribe line minus $.050 + .025 - .0$ this is dimension. **A=** _____

Line B: Length of head from the bottom to the shoulder. **B=** _____

Line C: Subtract B from A. **C=** _____

Line D: Add $.25$ to C. **D=** _____

Line E: Measure step on old drawbar. **E=** _____

Line F: With spacer on old drawbar measure from the bottom of the spacer to the end of the threaded end. **F=** _____

Machine the spacer blank (provided with the universal kit) to match the blue print of the spacer made in previous steps.

With the new spacer on the new drawbar, check all head dimensions. Measure and mark dimension **F**. Cut excessive amount off threads and chamfer.

Grease spline head, washer top and bottom, and threads on drawbar. Reinstall and proceed with power unit installation.

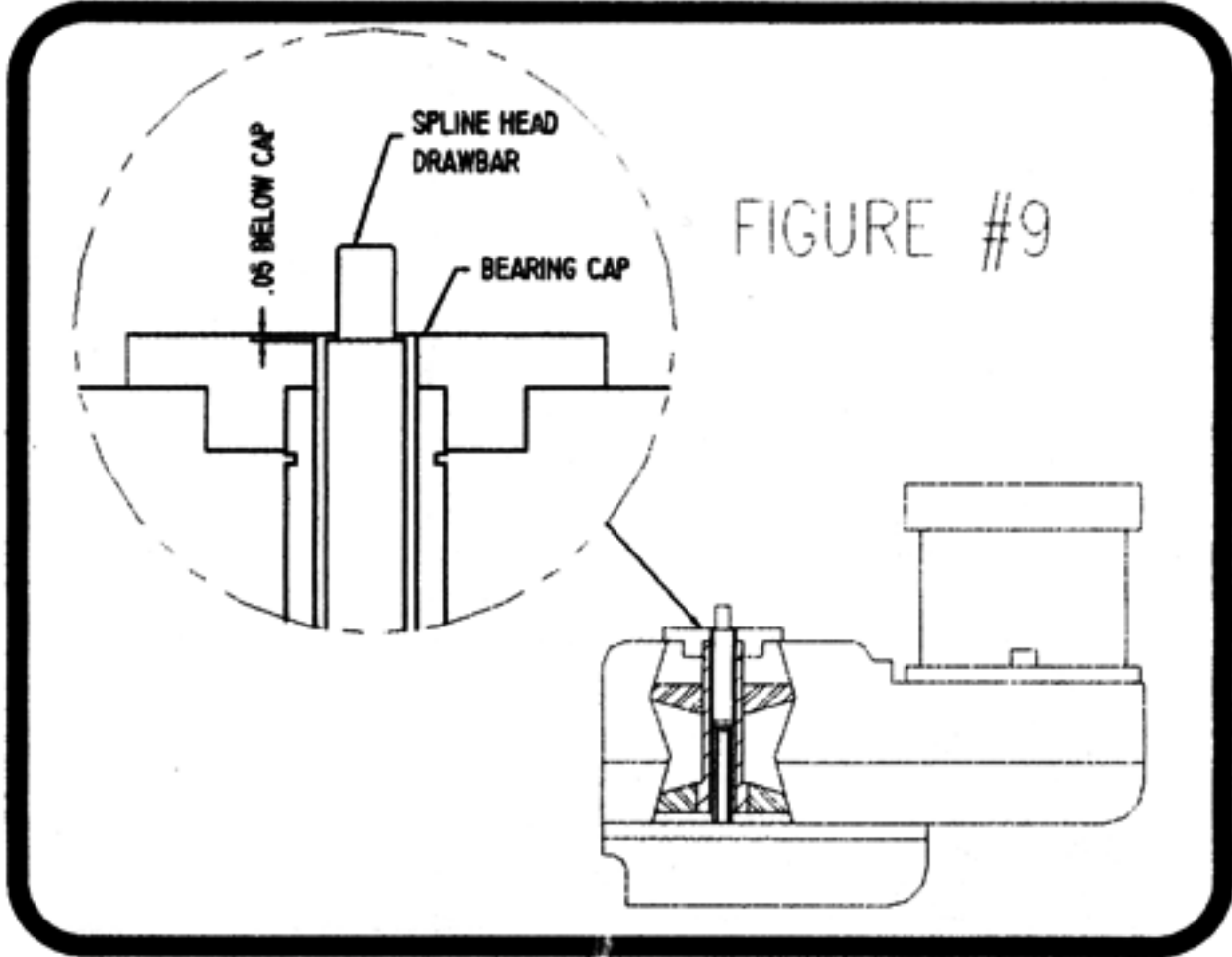

- A. _____
- B. _____
- C. _____
- D. _____
- E. _____
- F. _____
- G. _____

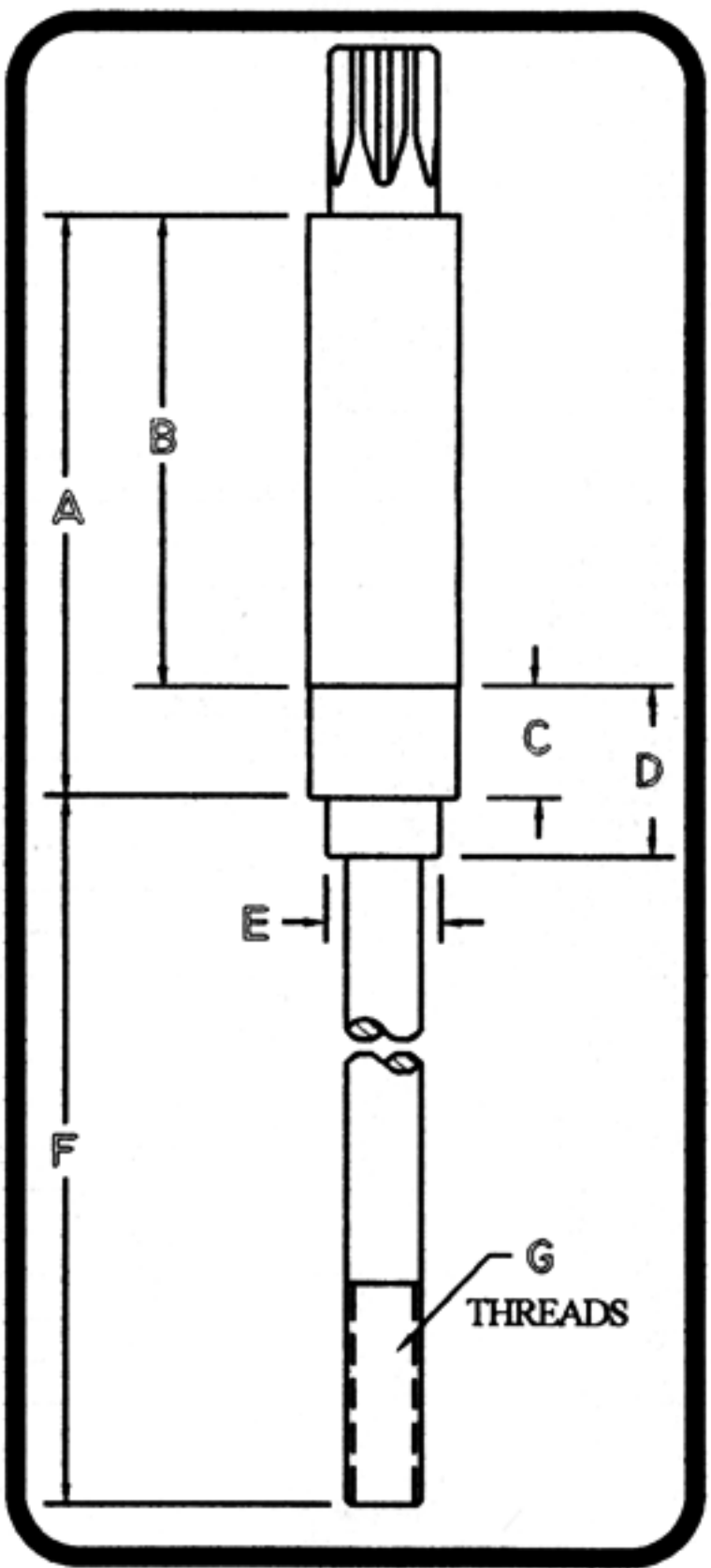

Parts List

NO	P/N	DESCRIPTION	REQ.
1	K010005	90° FITTING	5
2	D030006	SHCS	3
3	TR-200	SHUTTLE VALVE CAP	1
4	TR-202	GASKET	1
5	TR-203	PIN	1
6	TR-204	TOP END PLATE	1
7	TR-205	BEARING	2
8	TR-206	ROTOR BLADE	6
9	TR-207	ROTOR	1
10	TR-208	CYLINDER	1
11	TR-209	BOTTOM PLATE	1
12	TR-210	PIN	1
13	TR-211	HAMMER PIN	1
14	TR-212	HAMMER CAGE	1
15	TR-213	DRIVE CAM	1
16	TR-214	HAMMER DOG	1
17	TR-215	ANVIL	1
18	TR-216	ANVIL COLLAR	1
19	TR-217	ANVIL BUSHING	1
20	TR-218	HOUSING	1
21	A020001	NYLON BALL	2
22	D120001	NYLON WASHER	2
23	K010001	MUFFLER	1
24	F010001	SPRING	1
25	TR-219	SOCKET SLEEVE	1
26	TR-220	SOCKET	1
27	TR-221	HOUSING GUARD	1
28	L010002	O RING	1
29	D100001	DOWL PIN	3
30	TR-222	CYLINDER	1
31	D130001	RMET	1
32	TR-223	THRUST WASHER	2
33	TR-224	PISTON	1
34	L010001	O RING	1
35	D030004	SHCS	3
36	D030003	SHCS	3
37	D060002	1/4 LOCK WASHER	1
38	TR-225	BASE PLATE	1
39	D030005	SHCS	4
40	L010003	O RING	1
41	D090003	FHCS	4
42	TR-235	FACE PLATE	1
43	TR-226	IN BUTTON	1
44	TR-227	OUT BUTTON	1
45R	TR-228	OUT VALVE ASS'Y	1
45L	TR-229	IN VALVE ASS'Y	1
46	D080001	#10 HEX NUT	4
47	D060001	#10 LOCK WASHER	4
48	D030001	SHCS	2
49	K020004	3/8 X 10 FT. TUBING	1
50	K030001	PIPE PLUG	1
51	TR-230	CONTROL HEAD BRACKET	1
52	D030002	SHCS	2
53	K010006	STRAIGHT FITTING	1
54	TR-231	F.L.R. ASS'Y	1
55	DB-????	DRAWBAR ASS'Y (MODEL)	1
56	D090001	SHCS METRIC	3
57	D090002	SHCS METRIC	2



